



Grid-price-dependent Energy Management of a Building Supplied by a Multisource System Integrated with Hydrogen

M. Rouholamini*, M. Mohammadian

Department of Electrical Engineering, Shahid Bahonar University, Kerman, Iran

PAPER INFO

Paper history:

Received 11 September 2015

Received in revised form 06 January 2016

Accepted in 28 January 2016

Keywords:

Hybrid System

Power Management

Fuel Cell

Electrolyzer

Wind Turbine

Photovoltaic Array

Interior Search Algorithm

ABSTRACT

This paper studies power management in a grid-tied hybrid energy system consisting of photovoltaic array, wind turbine, fuel cell, electrolyzer, hydrogen storage tank and a combinational heating system to supply the thermal and electrical demand of a building. Moreover, the hybrid system is capable of exchanging power with local grid. Thus, variable daily buying and selling tariffs are also taken into account so as to cover a wide range of operational conditions. The thermal demand is supplied by both electric heating system and the fuel cell exhaust heat. The paper formulates the matter in the form of a nonlinear constrained optimization problem and then evaluates several well-known heuristic optimization techniques. The performance of each of these algorithms is discussed in detail and the elite algorithm is introduced. Furthermore, the effect of the initial charge of the hydrogen storage tank on total operation cost and also charge remained are fully discussed. In order to fulfill this intention, a novel criterion is presented to determine the optimal initial charge. The validation of the results will be implemented based on simulations.

doi: 10.5829/idosi.ije.2016.29.01a.06

NOMENCLATURE

C_t	Total operation costs (\$)	p_{th}^i	Thermal recovered power from fuel cell at interval i (kw)
$cost_m^i$	Maintenance costs during i^{th} time interval (\$)	p_g^i	Electrical power exchanged with local grid (kw)
D_e^i	Electrical demand during i^{th} time interval (kw)	p_{EL}^i	Electrolyzer electrical power consumption at interval i (kw)
D_{th}^i	Thermal demand during i^{th} time interval (kw)	PLR_i	Part load ratio of fuel cell at interval i (kw)
D_e^{max}	Customer's contract demand	r_{th}^i	Thermal to electrical power ratio at interval i
L/h	Liter per hour	soc_o	Initial state of charge of hydrogen tank (%)
MDT	Maximum down time limit (interval)	soc_{end}	Final state of charge of hydrogen tank (%)
MUT	Maximum up time limit (interval)	soc_{min}	Minimum limit of state of charge of hydrogen tank (%)
N^{max}	Maximum number of starts-stops	soc_{max}	Maximum limit of state of charge of hydrogen tank (%)
$N_{start-stop}$	Number of starts-stops of fuel cell	soc_i	State of charge of hydrogen tank at interval i (%)
n	Number of time intervals	\bar{T}	Duration of time interval (min)
p_w^i	Wind turbine power production at interval i (kw)	T_{i-1}^{on}	Duration in which fuel cell is continuously on
p_w^r	Rated power of wind turbine (kw)	T_{i-1}^{off}	Duration in which fuel cell is continuously off
p_s^i	Photovoltaic array power production at interval i (kw)	t_{buy}^h	Purchasing tariff in h^{th} hour (\$/kwh)
p_s^r	Rated power of Photovoltaic array (kw)	t_{sell}^h	Selling tariff in h^{th} hour (\$/kwh)
p_{EL}^{min}	Minimum limit of consumption power of electrolyzer (kw)	U_i	Equal 1 if fuel cell is on and zero if it is off
p_{EL}^{max}	Maximum limit of consumption power of electrolyzer (kw)	η_e^i	Electric efficiency of fuel cell in interval i
p_{FC}^{min}	Minimum electric generation output of fuel cell (kw)	η_H	Electric heating system efficiency
p_{FC}^{max}	Maximum electric generation output of fuel cell (kw)	Δp_{FC}^u	Ramp up rate limit of fuel cell (kw/min)
\bar{P}_H	Price of hydrogen (cent/Nl)	Δp_{FC}^d	Ramp down rate limit of fuel cell (kw/min)
p_{FC}^i	Fuel cell electrical power production at interval i (kw)	Δp_{EL}^u	Ramp up rate limit of electrolyzer (kw/min)
p_a	Internal consumption power of fuel cell (kw)	Δp_{EL}^d	Ramp down rate limit of electrolyzer (kw/min)

*Corresponding Author's Email: m.rouholamini@eng.uk.ac.ir (M. Rouholamini)

Please cite this article as: M. Rouholamini, M. Mohammadian, Grid-Price-Dependent Energy Management of a Building Supplied by a Multisource System Integrated with Hydrogen, International Journal of Engineering (IJE), TRANSACTIONS A: Basics. Vol. 29, No. 1, (January 2016) 40-48

1. INTRODUCTION

At present the main contribution of energy production in the world is still from fossil resources [1]. Therefore, providing stable and eco-friendly energy has been the developmental landscape of so many countries. The growing consumption and decreasing access to natural resources result in increase in the price of energy. Obviously, in such circumstances, renewable energy sources are being considered [2]. Meantime, the sun and wind are the two renewable energy resources which are lionized because of their ease of access and inexhaustibility [3]. However, producing energy from aforesaid resources is influenced by climatic and geographical conditions and this is considered as a challenge for sustainable generation [4]. In order to deal with such a kind of unsustainability, it is possible that energy conversion be done in the process of providing energy. For example, pumped-storage power plants pump water to a high altitude during light-load hours so that its potential energy can be used in peak hours to operate a hydro-generator, and generate power. Other conversions of energy can also be used for electrical energy storage. However, the most efficient type of conversion is gas into electrical power and vice versa. For instance, when energy exceeds consumption, hydrogen can be produced and stored at a high level of efficiency so as to be used as fuel for a fuel cell in case of energy shortage [5].

Some recent studies prove that placing fuel cell next to a wind turbine and a photovoltaic array can form an appropriate structure as a sustainable energy source [6-9].

As mentioned previously, a hybrid energy system has degrees of freedom in determining the contribution of each subsystem in comparison with a single source system that leads to an increase in the operational efficiency. Energy production in these structures is significantly more reliable and is not related to time or geographical conditions [5].

Accordingly, in this paper, the system under study includes both fuel cell and electrolyzer. The proposed hybrid structure is much more sustainable than those presented in previous researches. Moreover, this system is capable of exchanging power with local grid. The system satisfies both thermal and electrical load of a building. In other words, the system acts as a CHP generation system. In order to implement optimal energy management of the system in the form of an optimization problem, different well-known optimization techniques are utilized and a comparative assessment of results is presented. Proposing a novel criterion for choosing the best value of initial state of charge of hydrogen tank is also discussed in this paper. The rest of the paper is organized as follows: In the

second section, the problem of optimal energy management is comprehensively discussed in the form of a constrained nonlinear optimization problem and its formulation in order to design an off-line energy management system. The configuration of the hybrid system under study is also described in this section. In the third section, the utilized heuristic optimization techniques are introduced. In addition to this, simulation results provided by the techniques, those obtained by the elite algorithm in particular, are also proposed. Finally, conclusions are presented in section four

2. THE CONFIGURATION OF THE SYSTEM UNDER STUDY

The current paper discusses a grid-tied hybrid structure in which wind turbine, photovoltaic array and fuel cell are responsible for supplying the thermal and power demand of a building. The generation system is also equipped with some accessories such as electrolyzer, electric heater, hydrogen storage tank and water reservoir. It is essential to note that energy management beside various subsystems constraints is highly affected by the quality of the connections of each element, such as series, parallel or switchable connection [10]. According to what was said, the configuration of the system under study is represented in Figure 1.

Since this paper is a continuation of the work initiated in an earlier paper, the technical features of all subsystems, the data related to wind speed and radiation intensity, electrical and thermal demand and also energy exchange tariffs with local grid have been chosen the same as [11]. The electricity trading tariffs and the main features of the subsystems have been presented in the form of Figure 8 and Tables 1-5 of [11], respectively.

A polymer exchange membrane (PEM) fuel cell has been used in this paper due to its particular characteristics. PEM fuel cell has a higher efficiency and lower ohmic losses; it is cheaper and faster than other types. Therefore, this type of fuel cell is usually preferred [11]. Since a fuel cell is dynamically a slow device, in some cases it is paralleled with a super capacitor or a battery to improve its dynamic behavior [5, 10, 12]. In order to consider the slow behavior of the fuel cell in the process of solving the energy management problem, ramp up/down rate limits, minimum up/down time limits and the maximum number of starts/stops are also considered in the model. Equations (1)-(3) present the model of the given fuel cell [13]. These relations link the electric output power of the fuel cell, thermal exhaust power and its efficiency to one another. The relationship between hydrogen consumption of the fuel cell and its output power follows a relatively linear relationship [10].

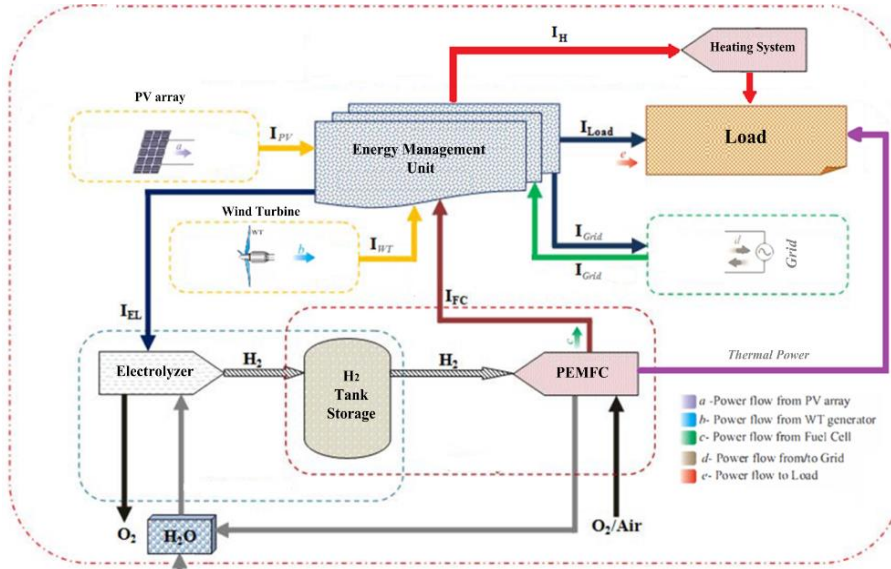

Figure 1. System configuration and power flows of the proposed system

$$\begin{cases} \eta_e^i = 0.2716 \\ r_{th}^i = 0.6801 \end{cases} \quad PLR_i \leq 0.05 \quad (1)$$

$$\begin{aligned} \eta_e^i &= 0.9PLR^5 - 2.99PLR^4 + \\ &3.65PLR^3 - 2.07PLR^2 \\ &+ 0.46PLR^1 + 0.37 \end{aligned} \quad PLR_i > 0.05 \quad (2)$$

$$\begin{aligned} r_{th}^i &= 1.0785PLR^4 - 1.9739PLR^3 + \\ &1.5PLR^2 - 0.2817PLR^1 + 0.68 \end{aligned}$$

$$p_{th}^i = r_{th}^i(p_{FC}^i + p_a) \quad (3)$$

2. 1. Problem Formulation and Objective Function

In this paper the period of the problem is a 24-h time horizon. In order to solve the optimization problem, the range of system parameters needs to be mapped to a discrete range using the sampling method. Here, the time interval of the samples is equal to 10 minutes while it was 15 minutes in [14, 15]. Equation (4) represents the essential relation of power balance which must be satisfied in each time interval. This equation verifies the configuration previously proposed in Figure 1.

$$p_g^i + p_{FC}^i + p_w^i + p_s^i = D_e^i + p_{EL}^i + \frac{\max(D_{th}^i - p_{th}^i, 0)}{\eta_H} \quad (4)$$

According to Equations (1)-(3), the thermal power produced by the fuel cell can be computed if its electric output power be known, so the unknown parameters in Equation (4) are $p_g^i, p_{FC}^i, p_{EL}^i$. Since the power balance equation itself presents a linear relation of these unknown parameters, the problem has two independent

variables. In the rest of the paper, it is assumed that the electric output power of the fuel cell and electrolyzer power consumption are the two independent variables of the optimization problem.

Expenses in this system include the maintenance, the cost of consumed hydrogen, the cost of buying electricity from the grid and the income is selling electricity to the local grid. So, the objective function can be defined as Equation (5). The first term of the objective function represents maintenance costs, the second term describes the power purchasing cost, the third term is related to the income obtained from selling electricity, the fourth term is a penalty which is responsible for exceeding the contract demand and finally the fifth term is related to the cost of consumed hydrogen fuel. It should be mentioned that due to the presence of the electrolyzer in the hybrid system, the price of stored hydrogen in the storage tank would be time-variable because both exchanging tariffs and power consumed by the electrolyzer are changing over time intervals, and this results in different prices for produced hydrogen. To avoid the complexities of calculating the spot price of the capsulated hydrogen, the difference between the primary and final state of charge of the hydrogen storage tank can be considered in calculating hydrogen consumption cost.

$$\begin{aligned} Cost &= \sum_{i=1}^n cost_m^i + \sum_{i=1}^n \bar{T} \cdot \max(p_g^i, 0) \cdot tr_{buy} \\ &\sum_{i=1}^n \bar{T} \cdot \min(p_g^i, 0) \cdot tr_{sell} + \\ &\sum_{i=1}^n \bar{T} \cdot \max(p_g^i - D_e^{max}, 0) \cdot tr_{buy-pen} + \\ &\bar{P}_H \cdot (soc_o - soc_{end}) \end{aligned} \quad (5)$$

The objective function presented in Equation (5) is subject to power balance equation defined by Equation (4) and inequality constraints defined by Equations (6)-(15). Equations (6) and (12) denote the minimum and maximum allowed generation and consumption limits of the fuel cell and electrolyzer, respectively. To cover the slow dynamic response of the fuel cell and electrolyzer, the set point of their power in the next time interval has been limited to a certain change by the use of ramp up/down rate limits. Therefore, Equations (7)-(8) and (13)-(14) are defined to formulate the aforesaid constraint. The other difficulty arising from the slow dynamic of these two subsystems are minimum up/down time limit and the maximum number of starts/stops in a given period. Equations (9) - (10) are responsible for applying these constraints in the problem formulation. It is clear that the maximum capacity of the hydrogen storage tank must be restricted to a critical limit. On the other hand, considering a security margin in the residual charge contained in the tank can increase system reliability. Based on these facts, Equation (15) is defined in order to cover this necessity.

$$P_{FC}^{min} \leq p_{FC}^i \leq P_{FC}^{max} \quad (6)$$

$$p_{FC}^i - p_{FC}^{i-1} \leq \Delta p_{FC}^u \quad (7)$$

$$p_{FC}^{i-1} - p_{FC}^i \leq \Delta p_{FC}^d \quad (8)$$

$$(T_{i-1}^{on} - MUT)(U_{i-1} - U_i) \geq 0 \quad (9)$$

$$(T_{i-1}^{off} - MDT)(U_i - U_{i-1}) \geq 0 \quad (10)$$

$$N_{start-stop} \leq N^{max} \quad (11)$$

$$P_{EL}^{min} \leq p_{EL}^i \leq P_{EL}^{max} \quad (12)$$

$$p_{EL}^i - p_{EL}^{i-1} \leq \Delta p_{EL}^u \quad (13)$$

$$p_{EL}^{i-1} - p_{EL}^i \leq \Delta p_{EL}^d \quad (14)$$

$$SOC_{min} \leq SOC_i \leq SOC_{max} \quad (15)$$

3. SURVEY ON OPTIMIZATION TECHNIQUES TO SOLVE POWER MANAGEMENT PROBLEM

The present optimal energy management of the grid-tied hybrid generation system is a constrained nonlinear optimization problem that is not easy to solve by relying on classical solution methods. Due to the complexity of solving such problems, engineers are often satisfied with a satisfactory solution instead of a global optimum. Therefore, several approaches have been suggested to

find a nearly optimal solution under an acceptable computational time period. Algorithms which can ensure finding good solutions in a given distance of the global solution are called approximate algorithms and those that can ensure finding a solution close to the optimum point considering a high probability are called probabilistic algorithms. Besides these two categories, there are some algorithms which have no guarantee in finding a solution, but according to the records of their results, they have greatly proposed the best tradeoff between computational effort and time. These optimization techniques are called heuristic algorithms. Generally, these algorithms have a kind of exclusive efficiency for a special category of optimization problems. However, the performance of some of them such as genetic algorithm is significantly wider. This matter made researchers pay attention to the various types of heuristic search during the last two decades. Hence, different optimization techniques have been presented and developed [16]. In other words, no heuristic algorithm has yet been presented that can be suitable for solving all optimization problems. Heuristic algorithms are popular among researchers due to four major reasons: simplicity, flexibility, not relying on derivativeness and convexity of fitness function and the ability of achieving the global optimum [16]. There are various heuristic techniques such as Genetic, Simulated Annealing, Cuckoo, Ant Lion Optimizer, Imperialist Competitive Algorithm, Dragonfly, Flower Pollination, Gray Wolf, Interior Search, League Championship, Optic Inspired, and Particle Swarm Optimization which are either in use or have been introduced in the last two years. According to the performance of these algorithms in solving energy management optimization problem, eight of them showed better results than the others. In the following, the effectiveness and robustness of these eight algorithms over the optimal power management problem are discussed briefly. The principles of the optimization idea of the aforementioned techniques have been fully described in literature [16-20].

3. 1. Simulation Results This section presents the simulation results of energy management in the hybrid system. The energy management has been implemented by using the optimization algorithms described above. The data related to the irradiation, wind speed and the technical information of the subsystems were presented in the previous sections. In order to make an appropriate comparison of the different algorithms, the same setting must be used. Therefore, the mentioned techniques must have the same starting point and population size with a certain number of iterations. Figure 2 shows the convergence profiles of different algorithms in which the number of iterations is equal to 2000. In the following, the performance of each of these techniques

over power management optimization problem is briefly discussed.

Genetic Algorithm (GA): According to Figure 2, the convergence curve of this algorithm ceaselessly follows a continuous and downward slope during the simulation period which is not observed in any of the other algorithms. From performance point of view, this algorithm ranks as the second best among all.

Simulated Algorithm (SA): Although the efficiency of this algorithm is undeniable in solving the complex engineering problems, in this case this algorithm is the most deficient. This could verify that the efficiency of a heuristic algorithm is usually restricted to an exclusive category of optimization problems which was mentioned before.

Cuckoo Algorithm: In the same manner of GA, the convergence profile of this algorithm follows a downward and continuous movement though not as efficient as that of GA.

Flower Pollination Algorithm (FA): By focusing on Figure 2, it can be observed that this algorithm would be the best algorithm if the number of iterations was restricted to a number around 100. That is to say, although the algorithm shows a prodigious performance during the initial iterations, the motivation of the algorithm decreases gradually, insofar as it finally meets the fourth rank among all.

Gray Wolf and Imperialist Competitive algorithms (GWO & ICA): These two algorithms have shown their inability by ending at two local minima of approximately the same value.

Interior Search Algorithm (ISA): Based on what Figure 3 indicates, the efficiency of this algorithm in finding the best solution is quite obvious. The algorithm has been nearly the most elite of all from the initial iterations to end. The behavior of the algorithm is in such a way in which finding a better solution is promising and highly expected. The performance of this optimization technique is so clear that there is no hesitation for choosing it as the most efficient algorithm. For the same reason, only the simulation results obtained by this algorithm are presented in the following.

Optic Inspired Optimization (OIO): In initial iterations, this technique treats as well as flower pollination algorithm. In other words, in the beginning the algorithm introduces itself as a significantly powerful optimization technique, but the algorithm reaches to a local minimum by increasing the number of iterations. From nearly the 1200th iteration to end, the convergence profile of this algorithm and SA more or less match each other. OIO meets the second position, after SA, from the perspective of deficiency.

It is noticeable since all the algorithms discussed above are heuristic; they contain an unavoidable inherent uncertainty. That is to say, a heuristic would not explore all possible states of the optimization problem, or would begin by exploring the most likely ones, so it may fail to find a better solution. Based on this fact, a heuristic technique might propose a nearly more optimal solution through reimplementing. To avoid this case, the best solution found after several executions was chosen and showed in Figure 2 though reimplementations did not present so different results. This means that despite the presence of some stochastic movements in the nature of these algorithms, their performance is chiefly influenced by the structure of the optimization algorithm not the number of runs. Table 1 presents the numerical results of the different algorithms in terms of cost and computational time. Regarding the robustness of ISA (Figure 2 and Table 1) and by considering a compromise between the computational effort and the time required the final results to which the algorithm leads are illustrated in Figure 3. From what Figure 3 shows, it can be argued that low buying tariff at early hours has made the electrolyzer produce hydrogen in this period. That is because the electrolyzer can produce hydrogen in these hours with a lower price than that of a hydrogen fuel station. Due to the slow dynamic of the electrolyzer that was earlier applied to the problem formulation in the forms of Equations (13) and (14), the electrolyzer has started with a growing consumption. This conservative response is also seen in all other upward and downward changes of the electrolyzer consumption. Since the purchasing tariff is seriously low during the initial hours, the electrolyzer is strongly attempting to produce and store hydrogen with its maximum capacity. Later, by increasing the buying tariff, the electrolyzer is less prone to generate hydrogen. The lack of free space for hydrogen storage could be another cause for this reluctance.

TABLE 1. The numerical comparison of the utilized optimization algorithms under the conditions in which the starting point, population size and also the number of iterations is the same for all algorithms

Algorithm	GA	SA	Cuckoo	FPA	GWO	ICA	ISA	OIO
Elapsed Time (s)	1096	124	2641	1142	1707	1817	1835	48
Cost (\$)	6.323	6.890	6.562	6.591	6.726	6.758	5.666	6.863

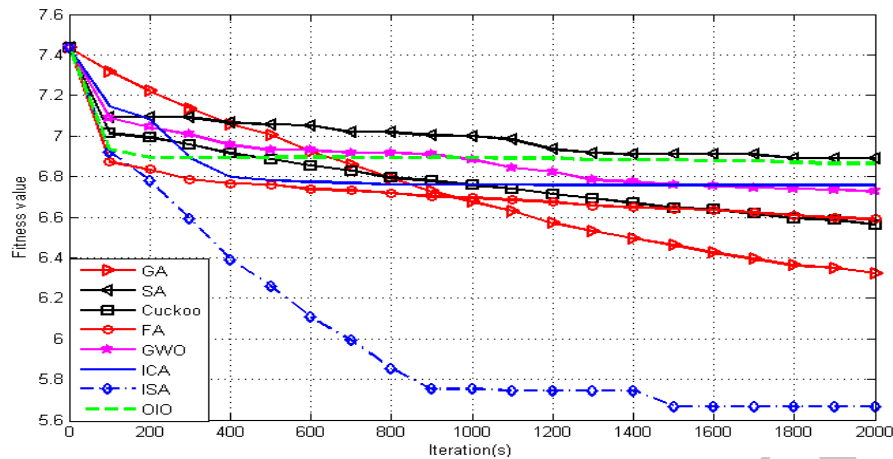

Figure 2. The convergence profiles of the utilized optimization algorithms under the conditions in which the starting point, population size and also the number of iterations is the same for all algorithms

The production of hydrogen by the electrolyzer is also seen in the last hours because there is a further decrease in buying tariff. At the period 1- 7 o'clock, the wind turbine is the only generator and the electrical and thermal load is mainly satisfied by the local grid. As Figure 3 shows, the electric heater is supplying the heat demand during the mentioned period while the fuel cell is shut down. This situation has resulted in a great amount of purchased power from the local grid because there is no exhaust heat recovery via fuel cell during this period.

After the 7th hour, with an increase in purchasing tariff, the fuel cell begins to generate power through consuming hydrogen. The fuel cell cooperates in supplying both electrical and heat load, so that the power purchased from the local grid is highly reduced. In hours 7-15 in spite of the effort of the fuel cell to supply thermal load, it is not fully met. Therefore, the electric heating system is still trying to compensate this shortage, which has been shown as a gray area in Figure 3. Since almost the entire electrical and thermal load is being met by the fuel cell during 15-20 o'clock, local generation exceeds the total demand some of the time. In such a case, any excess electricity is fed back into the grid which is largely the power produced by the wind turbine in this period. Like what was argued about the quality of the electrolyzer response, the slope of the changes of the power produced by the fuel cell is also slow and there is no sudden variation. Equations (7) and (8) are responsible for this behavior of the fuel cell which were previously discussed. The hours, during which the fuel cell has participated with its maximum capacity in providing load corresponds to high buying tariffs. The power produced by the solar array has led to a decline in the fuel cell production within hours 10-15. It is really essential to note that there is no time interval in which both injecting energy to the grid and

consuming power by the electrolyzer is simultaneously observed. This important note validates the problem formulation and simulation results.

It is clear that the hydrogen storage tank needs a recharge after a few days. The initial state of charge (SOC) can postpone the recharge or vice versa that was broadly studied in [11]. Authors of the mentioned article demonstrated that load supplying cost and time to recharge in such a hybrid generation system are highly influenced by the primary SOC of hydrogen storage tank. As it was mentioned previously in section 2, we assumed max/min limit for SOC. One can say that current SOC must be higher than a certain charge during all time intervals and another designer can say the value of current SOC is not important, but final SOC must be above a certain limit. Since the first claim is a more conservative approach in terms of reliability, it was considered in the problem simulation in this paper. The simulation results previously showed in Figure 3 were based on this presupposition that the initial SOC (SOC_0) is equal to 90%. However, choosing this particular value was not reasoned. Figure 4 depicts both final SOC of the hydrogen storage tank and total operation cost with respect to different values for SOC_0 .

It is obvious that the enlargement of remained charge (final SOC) in the tank is satisfying for the operator of the system, because it postpones time to recharge. On the other hand, minimum operation cost is a purpose which is essentially followed in energy management. Therefore, a tradeoff must be considered. The ratio of cost to remained charge could be an efficient and strategic criterion to determine the appropriate value of SOC_0 . According to Figure 4, the best value of the index (the minimum value) is nearly proved for $SOC_0 = 90\%$. That is why the simulation results were initially presented with emphasis on $SOC_0 = 90\%$.

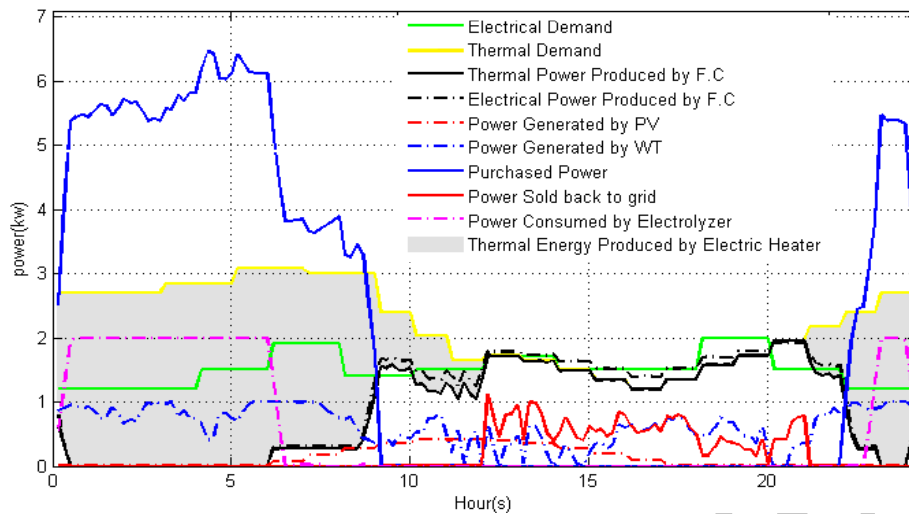

Figure 3. Optimization problem results beside electrical and thermal load profile in case $SOC_0 = \%90$

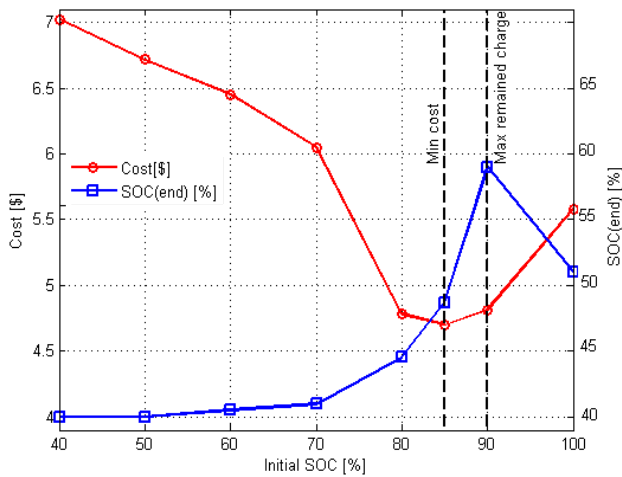

Figure 4. Changes of final SOC and total operation cost with respect to different values of initial SOC

Since the minimum cost occurs when initial charge is equal to 85%, a 5-percent step size is regarded between 80-90%. It should not be neglected that Figure 4 is to say although the SOC, in which the maximum value of the charge remained is met, is not necessarily corresponding with the point in which the minimum operating cost is provided; the distance between these two points is not very high. Furthermore, by focusing on Figure 4, one can understand that almost there is no segment in which both cost and remained charge profiles moves in the same direction. The style of the objective function formulation verifies this observation (Equation (5)).

The minimum operation cost obtained in [11] with $SOC_0 = 90\%$ using gravitational search algorithm was equal to \$4.819, while the current technique (ISA) presents the total operation cost = \$4.765.

These optimizations were carried out under MATLAB R2013a (8.1.0.604), 32-bit on a system running at 2.26 GHz (Intel Core i5) with 4 GB of RAM.

4. CONCLUSION

Through this paper, first an overview of energy management in hybrid energy systems was discussed and then a sustainable and grid-connected structure of these kinds of systems was proposed which consists of wind turbine, photovoltaic array, fuel cell, electrolyzer, combinational heater and hydrogen storage tank. The aforementioned system was capable of trading power with local grid with variant tariffs through a 24-h time horizon. This system guaranteed to supply a domestic load where the thermal demand of the building was met through recovering exhaust heat of the fuel cell and the electric heater. Several well-known heuristic algorithms were used in order to solve the energy management optimization problem in the system under study as a nonlinear and constrained one. Based on the simulation results, Interior Search Algorithm (ISA) distinctly proposed the most efficient results with great suitability in comparison with other algorithms. Furthermore, the role of initial charge of the hydrogen storage tank in total operation cost was also argued. According to the results obtained, choosing an inappropriate initial charge for the hydrogen storage tank would have both increased energy supply cost intensively and decreased the reliability associated with the hybrid system. Since the effect of this parameter on the operation cost and the final state of charge of the hydrogen storage tank was in a case that it was always improving one and weakening the other, a simple yet robust criterion was introduced and applied in order to choose the optimal initial state of

charge. The optimal point of this index is constantly affected by the technical features of the system components, power exchange tariffs with the grid and also the electrical and thermal load profile.

5. REFERENCES

1. Najafpour, G., Mehdizadeh, S. and Asadi, M., "Environmental impact of fossil fuel utilization in neka thermal power plant", *International Journal of Engineering, Transactions B: Applications*, Vol. 23, No. 2, (2010), 115-120.
2. Yazici, M.S., Yavasoglu, H.A. and Eroglu, M., "A mobile off-grid platform powered with photovoltaic/wind/battery/fuel cell hybrid power systems", *International Journal of Hydrogen Energy*, Vol. 38, No. 26, (2013), 11639-11645.
3. Deshmukh, M. and Deshmukh, S., "Modeling of hybrid renewable energy systems", *Renewable and Sustainable Energy Reviews*, Vol. 12, No. 1, (2008), 235-249.
4. Zahedi, A., "Technical analysis of an electric power system consisting of solar pv energy, wind power, and hydrogen fuel cell", in Power Engineering Conference, AUPEC. Australasian Universities, IEEE. (2007), 1-5.
5. Ipsakis, D., Voutetakis, S., Seferlis, P., Stergiopoulos, F. and Elmasides, C., "Power management strategies for a stand-alone power system using renewable energy sources and hydrogen storage", *International Journal of Hydrogen Energy*, Vol. 34, No. 16, (2009), 7081-7095.
6. Alam, M.S. and Gao, D.W., "Modeling and analysis of a wind/pv/fuel cell hybrid power system in homer", in Industrial Electronics and Applications, ICIEA. 2nd IEEE Conference on, (2007), 1594-1599.
7. Hakimi, S., Tafreshi, S.M. and Kashefi, A., "Unit sizing of a stand-alone hybrid power system using particle swarm optimization (PSO)", in Automation and Logistics, IEEE International Conference. (2007), 3107-3112.
8. Lagorse, J., Simoes, M.G., Miraoui, A. and Costerg, P., "Energy cost analysis of a solar-hydrogen hybrid energy system for stand-alone applications", *International Journal of Hydrogen Energy*, Vol. 33, No. 12, (2008), 2871-2879.
9. Uzunoglu, M., Onar, O. and Alam, M., "Modeling, control and simulation of a pv/fc/uc based hybrid power generation system for stand-alone applications", *Renewable Energy*, Vol. 34, No. 3, (2009), 509-520.
10. Ranjbar, M.R. and Mohammadian, M., "Economic analysis of hybrid system consists of fuel cell and wind based chp system for supplying grid-parallel residential load", *Energy and Buildings*, Vol. 68, No., (2014), 476-487.
11. Rouholamini, M. and Mohammadian, M., "Energy management of a grid-tied residential-scale hybrid renewable generation system incorporating fuel cell and electrolyzer", *Energy and Buildings*, Vol. 102, No., (2015), 406-416.
12. Silva, S., Severino, M. and De Oliveira, M., "A stand-alone hybrid photovoltaic, fuel cell and battery system: A case study of tocantins, brazil", *Renewable Energy*, Vol. 57, No., (2013), 384-389.
13. El-Sharkh, M., Tanrioven, M., Rahman, A. and Alam, M., "A study of cost-optimized operation of a grid-parallel pem fuel cell power plant", *Power Systems, IEEE Transactions on*, Vol. 21, No. 3, (2006), 1104-1114.
14. El-Sharkh, M., Tanrioven, M., Rahman, A. and Alam, M., "Cost related sensitivity analysis for optimal operation of a grid-parallel pem fuel cell power plant", *Journal of Power Sources*, Vol. 161, No. 2, (2006), 1198-1207.
15. El-Sharkh, M., Tanrioven, M., Rahman, A. and Alam, M., "Impact of hydrogen production on optimal economic operation of a grid-parallel pem fuel cell power plant", *Journal of Power Sources*, Vol. 153, No. 1, (2006), 136-144.
16. Mirjalili, S., Mirjalili, S.M. and Lewis, A., "Grey wolf optimizer", *Advances in Engineering Software*, Vol. 69, No., (2014), 46-61.
17. Ardalan, Z., Karimi, S., Poursabzi, O. and Naderi, B., "A novel imperialist competitive algorithm for generalized traveling salesman problems", *Applied Soft Computing*, Vol. 26, (2015), 546-555.
18. Gandomi, A.H., "Interior search algorithm (isa): A novel approach for global optimization", *ISA transactions*, Vol. 53, No. 4, (2014), 1168-1183.
19. Kashan, A.H., "A new metaheuristic for optimization: Optics inspired optimization (OIO)", *Computers & Operations Research*, Vol. 55, No., (2015), 99-125.
20. Li, X. and Yin, M., "Modified cuckoo search algorithm with self adaptive parameter method", *Information Sciences*, Vol. 298, (2015), 80-97.

Grid-Price-Dependent Energy Management of a Building Supplied by a Multisource System Integrated with Hydrogen

M. Rouholamini, M. Mohammadian

Department of Electrical Engineering, Shahid Bahonar University, Kerman, Iran

PAPER INFO

چکیده

Paper history:

Received 11 September 2015

Received in revised form 06 January 2016

Accepted in 28 January 2016

Keywords:

Hybrid System

Power Management

Fuel Cell

Electrolyzer

Wind Turbine

Photovoltaic Array

Interior Search Algorithm

مقاله‌ی حاضر مبحث مدیریت انرژی در یک سیستم هیبریدی متصل به شبکه متشکل از آرایه‌ی فتوولتائیکی، توربین باد، پیل سوختی، الکتروولایزر، تانک ذخیره هیدروژن و یک سیستم گرمایش ترکیبی به منظور تامین دیمانند الکتریکی و گرمایشی یک ساختمان را مد نظر قرار می‌دهد. سیستم هیبریدی تحت بررسی قابلیت تبادل توان با شبکه محلی را نیز داراست. از این رو تعرفه‌های خرید و فروش انرژی نیز با هدف پوشش دامنه‌ی وسیعی از مدهای مختلف بهره‌برداری لحاظ گردیده‌اند. دیمانند گرمایشی از طریق حرارت بازیافتی از پیل سوختی و نیز انرژی گرمایی تولیدی توسط سیستم گرمایش الکتریکی تامین می‌گردد. این مقاله مبحث مدیریت انرژی را در قالب یک مساله‌ی بهینه‌سازی غیرخطی فرموله کرده و سپس نسبت به ارزیابی کارایی چندین الگوریتم بهینه‌سازی فراابتکاری در حل مساله‌ی مذکور مبادرت می‌کند. کارایی هر یک از الگوریتم‌ها به‌طور مبسوط بحث خواهد شد و کارآمدترین آنها معرفی می‌شود. علاوه بر این، نقش مقدار شارژ اولیه‌ی کپسول ذخیره‌سازی هیدروژن بر روی هزینه‌های بهره‌برداری از سیستم به‌طور جامع بررسی می‌شود. به منظور انجام این بررسی، یک شاخص ابتکاری برای تعیین مقدار بهینه‌ی شارژ اولیه‌ی تانک ذخیره‌ی هیدروژن ارائه می‌شود. صحت‌گذاری نتایج بر اساس نتایج شبیه‌سازی دنبال خواهد شد.

doi: 10.5829/idosi.ije.2016.29.01a.06

Archive

Surf and download all data from SID.ir: www.SID.ir

Translate via STRS.ir: www.STRS.ir

Follow our scientific posts via our Blog: www.sid.ir/blog

Use our educational service (Courses, Workshops, Videos and etc.) via Workshop: www.sid.ir/workshop