

SID



سرویس های ویژه



سرویس ترجمه تخصصی



کارگاه های آموزشی



بلاگ مرکز اطلاعات علمی



عضویت در خبرنامه



فیلم های آموزشی

کارگاه های آموزشی مرکز اطلاعات علمی جهاد دانشگاهی



کارگاه آنلاین آشنایی با پایگاه های اطلاعات علمی بین المللی و ترند های جستجو

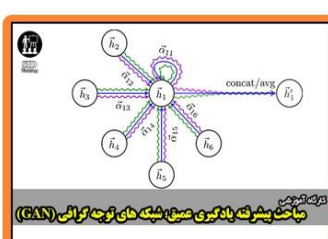

مباحث پیشرفته یادگیری عمیق؛ شبکه های توجه گرافی (Graph Attention Networks)



کارگاه آنلاین مقاله نویسی IEEE و ISI ویژه فنی و مهندسی

Optimal Controller for Single Phase Island Photovoltaic Systems

Mohammad Esmail Akbari¹, Noradin Ghadimi^{2,*}

¹Department of Electrical Engineering, Ahar Branch, Islamic Azad University, Ahar, Iran
Email: m-akbari@iau-ahar.ac.ir
Young Researchers and Elite Club

²Ardabil Branch, Islamic Azad University, Ardabil, Iran
*Corresponding author Email: Noradin.1364@gmail.com

ABSTRACT

Increasing of word demand load caused a new Distributed Generation (DG) to enter to power system. One of the most renewable energy is the Photovoltaic System. It is beneficial to use this system in both separately as well as connected to power system using power electronics interface. In this paper an optimal PID controller for Photovoltaic System systems has been developed. The optimization technique is applied to PID optimal controller in order to control the voltage of Photovoltaic System against load variation, is presents. Nonlinear characteristics of load variations as plant input, Photovoltaic System operational behavior demand for high quality optimal controller to ensure both stability and safe performance. Thus, Honey Bee Mating Optimization (HBMO) is used for optimal tuning of PID coefficients in order to enhance closed loop system performance. In order to use this algorithm, at first, problem is written as an optimization problem which includes the objective function and constraints, and then to achieve the most desirable controller, HBMO algorithm is applied to solve the problem. In this study, the proposed controller is applied to the closed loop photovoltaic system behavior. Simulation results are done for various loads in time domain, and the results show the efficiency of the proposed controller in contrast to the previous controllers.

KEYWORDS: Photovoltaic System- HBMO- Optimal Controller- PID Controller

1. INTRODUCTION

According to an increasing consumption of fossil fuels in recent years and their limited resources, it is very vital to use unlimited natural energy resources such

as water, wind and sun. A very common application of such resources is electrical energy generation. The distributed generation (DG) units have become more and more competitive against the conventional centralized system by

successfully integrating new-generation technologies and power electronics and attracted many customers from industrial, commercial, and residential sectors.

DGs generally refer to distributed energy resources (DER) including photovoltaic, fuel cells, micro turbines, small wind turbines, etc. A MicroGrid (MG) basically comprises coordinated operation and control of DER along with a controllable load and storage devices such as battery and energy capacitors [1, 2]. Most of these DERs are connected to the utility grid by a power electronic converter system that generally uses voltage source converters (VSC) [2]. The salient advantage of a MG is that it can be operated in the connected mode to utility grid as well as the islanding mode [3, 4]. The existing standards do not permit DERs to be utilized in island mode. This is called anti-islanding protection. As the anti-islanding protection is mainly applied to ensure personal safety at the grid end, if the island does not contain any part of the grid the DG unit can operate as an uninterruptible power supply (UPS) for load [5].

The main challenge encountered in the operating of DER with its local load in both connected and island mode are that the DER should outfit with a VSC capable of estimating some conditions such as: VSC should be able to regulate the voltage and frequency of the MG bus to a nominal value, VSC should supply a predetermined load, regardless to plant

parameter changes and also, VSC control must be implemented using only locally feedback.

Most of the previous researches in this field are based on adding a dq-current control strategy for multiple DER units in the islanding mode according to droop characteristics of reactive-power/voltage and active-power/frequency. Independent control of active and reactive powers to improve transient response in islanding time as well preserving of angle stability and voltage quality in the micro-grid was proposed in [6]. Transients and the small-signal dynamic model of a microgrid including the conventional and electronically interfaced distributed resources were investigated and presented in [7-9]. Ref [8] is introduced a droop-controlled imbalance method based on the reactive power by the negative-sequence current and the positive-sequence line voltage. The proposed method is called Q^-_G droop control and can be integrated with the conventional active-power/frequency and reactive-power/voltage control. The presented control strategy is based on the active-power/frequency and reactive-power/voltage control and load dynamics is not directly incorporated in the control loop. Thus, these methods lead to poor dynamic responses for large and fast load changes; even it may result in voltage/frequency instability [4] for some cases.

In this paper an optimal-tuning PID controller for a photovoltaic system is

proposed based on Honey Bee Mating Optimization (HBMO) algorithm.

In this paper, a simple PID controller is used to control the output voltage of photovoltaic systems in islanding mode, except that this controller's coefficients are not obtained using trial and error method, but for optimization in this study the HBMO is adopted to obtain the coefficients but HBMO technique is utilized. Furthermore, it will be shown that the system response in the proposed controller is considerably faster while no fluctuations are mounted on the control or output signals.

This paper is organized as follows: in section 2 the photovoltaic system is explained. In section 3 the HBMO algorithm is described. Proposed controller is applied to mathematical plants in section 4. Section 5 shows the advantages of the proposed controller over classic controller. Finally, section 6 contains a conclusion of the proposed algorithm.

2. PHOTOVOLTAIC SYSTEM

The study system is shown in Fig 1, in which the DG has been depicted equally as a DC source and a VSC connected through a low pass filter to the local load. The total impedance of the low pass filter is displayed as R_t and L_t . The system parameters are given in Table 1. The system should be able to operate in an off - grid mode. In grid-connected mode, the intermediate VSC will be a current-controlled voltage source controller, i.e. The typical strategy operates for VSC unit. In this paper, the goal is to achieve a desirable controller, which is able to keep constant the load voltage in islanding mode for load variations. And because the generated energy by photovoltaic system is stored in a battery, therefore the photovoltaic system can be considered as a constant voltage source.

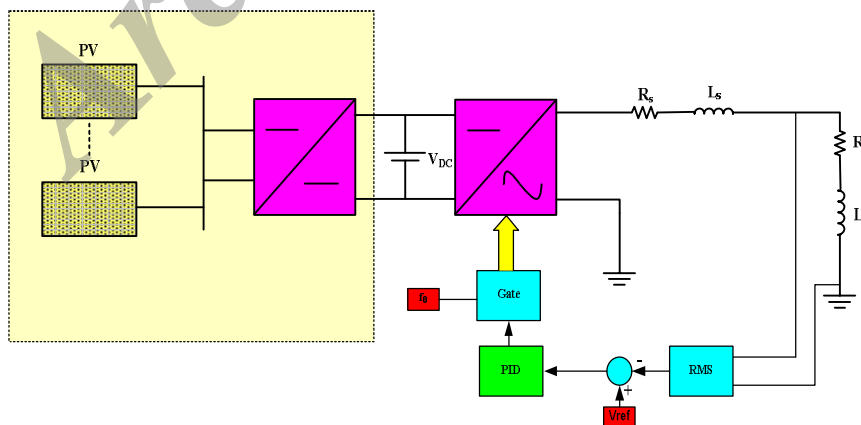

Fig.1. Photovoltaic system with battery, inverter and load

Table1. The value of the study system parameters

Parameter	Value
V_{DC}	350v
R_s	1 Ω
L_s	7mH
R_l	50 Ω
L_l	35mH
V_{ref}	220v
f_0	50HZ
Nominal Power	1KW
Nominal Frequency	50HZ

3. HBMO ALGORITHM

The honey bee is a social insect that can survive only as a member of a community, or colony. The colony inhabits an enclosed cavity. A colony of honey bees consist of a queen, several hundred drones, 30,000 to 80,000 workers and broods during the active season. A colony of bees is a large family of bees living in one bee-hive. The queen is the most important member of the hive because she is the one that keeps the hive going by producing new queen and worker bees [10]. Drones' role is to mate with the queen. Tasks of worker bees are several such as: rearing brood, tending the queen and drones, cleaning, regulating temperature, gather nectar, pollen, water, etc. Broods arise either from fertilized (represents queen or worker) or unfertilized (represents drones) eggs. The HBMO Algorithm is the combination of several different methods corresponded to a different

phase of the mating process of the queen. In the marriage process, the queen(s) mate during their mating flights far from the nest. A mating flight starts with a dance performed by the queen who then starts a mating flight during which the drones follow the queen and mate with her in the air. In each mating, sperm reaches the spermatheca and accumulates there to form the genetic pool of the colony. The queen's size of spermatheca number equals to the maximum number of matings of the queen in a single mating flight is determined. When the queen mates successfully, the genotype of the drone is stored. At the start of the flight, the queen is initialized with some energy content and returns to her nest when her energy is within some threshold of zero or when her spermatheca is full. In developing the algorithm, the functionality of workers is restricted to brood care, and therefore, each worker

may be represented as a heuristic which acts to improve and/or take care of a set of broods. A drone mates with a queen probabilistically using an annealing function as [11]:

$$P_{rob}(Q, D) = e^{-\frac{\Delta(f)}{s(t)}} \quad (4)$$

Where Prob (Q, D) is the probability of adding the sperm of drone D to the spermatheca of queen Q (that is, the probability of a successful mating); $\Delta(f)$ is the absolute difference between the fitness of D (i.e., $f(D)$) and the fitness of Q (i.e., $f(Q)$); and $S(t)$ is the speed of

the queen at time t . It is apparent that this function acts as an annealing function, where the probability of mating is high when both the queen is still in the start of her mating-flight and therefore her speed is high, or when the fitness of the drone is as well as the queen's. After each transition in space, the queen's speed, $S(t)$, and energy, $E(t)$, decay using the following equations:

$$S(t+1) = \alpha \times s(t) \quad (5)$$

$$E(t+1) = E(t) - \gamma \quad (6)$$

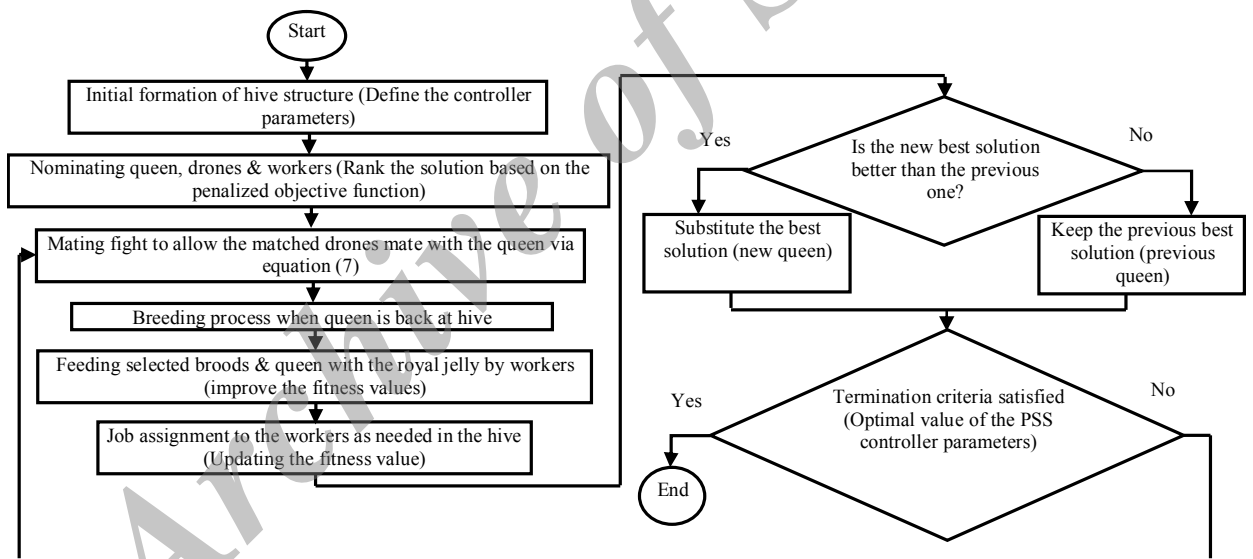

Fig. 2. Algorithm and computational flowchart of HBMO

Where α is a factor and γ is the amount of energy reduction after each transition. Also, Algorithm and computational flowchart of HBMO methods to optimize the photovoltaic controller parameters is presented in Figure.2.

Thus, HBMO algorithm may be constructed in the following five main stages:

1. The algorithm starts with the mating-flight, where a queen (best solution) selects drones probabilistically to form the spermatheca (list of drones). A

drone is then selected from the list at random for the creation of broods.

2. Creation of new broods by crossovering the drones' genotypes with the queen's.
3. Use of workers (heuristics) to conduct a local search on broods (trial solutions).
4. Adaptation of workers' fitness based on the amount of improvement achieved on broods.
5. Replacement of weaker queens by fitter broods.

4. CONTROLLER DESIGNING BASED ON HBMO

Due to develop of system controllers, the conventional controllers are used widely in power system applications. Making an application of conventional controllers is simple against the new controllers of power systems [12]. The PID controllers are widely used in most cases of power system controllers which compensate very well. One of the most benefits of

these controllers is the easily implementation in analog and digital systems. If these controllers are designed optimally, indubitable they become one of the most implemented controllers in modern systems. This paper introduces a new optimal PID controller, which is used by HBMO algorithm for designing the controller of photovoltaic systems in order to control output voltage. The overall controller schematic is shown in Fig. 3.

The PID general controller is expressed in equation (7) which the controller k_p, k_i, k_d parameters should be optimized using the proposed algorithm. In the load variations, it is obvious that the transient mode of the system depends on the controller parameters. The conventional controller designing method are not viable to be implemented because this system is an absolute nonlinear system. So these methods would have not efficient performance in the system.

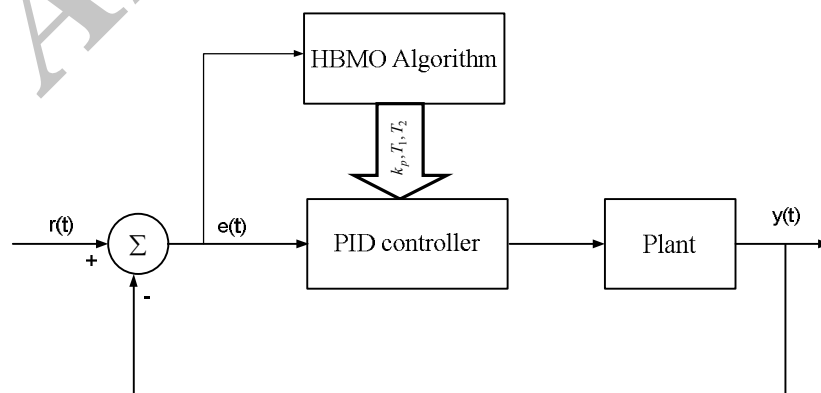

Fig. 3. Schematic of the proposed controller designing

$$G_c(s) = k_p + \frac{k_i}{s} + k_d s \quad (7)$$

In order to design a controller optimal controller using HBMO for the photovoltaic from the load variation

curve, we consider the worst condition for load design controllers for these conditions. Fig. 4, depicts the worst condition for load variation in the system.

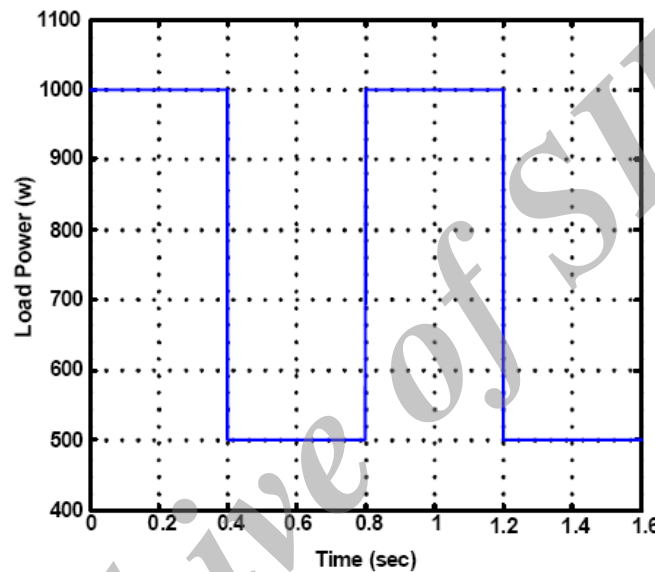

Fig. 4. Worst case of load variation

At first, problem should be written as an optimization problem and then by applying the proposed optimization method, the best PID controller is achieved. Selecting objective function is the most important part of this optimization problem. Because, choosing different objective functions may completely change the particle's variation state. In optimization problem we considered the voltage error signal in order to achieve the best controller.

$$J = \int_{t_{start}}^{t_{sim}} \left[V_{ref} - V_{out} \right] dt \quad (8)$$

Where, t_{sim} is the simulation time in which objective function is calculated, the V_{out} is the real voltage of turbine and V_{ref} is the reference voltage signal. We are reminded that whatever the objective function is a small amount in this case the answer will be more optimized. Each optimizing problem is optimized under a number of constraints. At this problem constraints should be expressed as:

$$Min J \text{ sub. to } \begin{cases} k_p^{\min} \leq k_p \leq k_p^{\max} \\ k_i^{\min} \leq k_i \leq k_i^{\max} \\ k_d^{\min} \leq k_d \leq k_d^{\max} \end{cases} \quad (9)$$

Where, k_i, k_d and k_p are in the interval [0.0001 10]. In this problem, the number of particles, the dimension of the particles, and the number of repetitions is selected 40, 3, 80, respectively. After optimization, results are determined as below:

$$\begin{aligned} k_p &= 0.00212 \\ k_i &= 0.0443 \\ k_d &= 0.00014 \end{aligned} \quad (10)$$

5. SIMULATION RESULTS

In this section, simulation results, which are performed for different loads and output power results, show the proposed controller robustness. The first load of the system is 550W and 120Var and the DG could supply the mentioned load. At instant $t = 0.4\text{sec}$, a load with active and reactive powers $P = 130\text{W}$ and $Q = 30\text{Var}$ respectively is added to the system and also the same amount of load in at $t = 0.8\text{sec}$ and $t = 1.2\text{sec}$ is added to the system and finally the active and reactive power of systems reach $P = 940\text{W}$ and is $Q = 210\text{Var}$, respectively. The conventional PID controller has initial and random values in proportional, integral and derivative coefficients as below:

$$\begin{aligned} k_p &= 0.018 \\ k_i &= 0.23 \\ k_d &= 0.01 \end{aligned} \quad (11)$$

System response to the mentioned variation is shown in Fig.4. The

instantaneous voltage variation is shown in Fig 5 (a). Instantaneous current due to load variation and active/reactive power of load are plotted in Fig 5 (b), (c), respectively.

In order to qualify the proposed controller, closed loop system responses to the input shown in Fig 6, are depicted in Figs 6 (a) through 6 (c). It is also desired to check whether the proposed controller is capable of smooth and robust response to load variation. Fig.6 (a) depict voltage signal of the load. According to these Figures can be said that the proposed controller is much more effective than a conventional PID controller. The proposed controller offers a fast response with almost zero overshoot. It could be easily seen that our controller behaves effectively and pretty fast when a load variation is applied.

5. CONCLUSION

In this paper, a novel method to control the photovoltaic system voltage in islanding mode was proposed. It was shown that these proposed methods, can explain instinct nonlinear behavior photovoltaic systems very well. At first, the conventional PID controller is used in order to control output voltage. Then, proposed method, which was used the HBMO optimization algorithm controller, was applied to control the voltage. Issues such as load variations which are associated with all practical systems ask for model-free. The proposed controller not only increases the closed system bandwidth, but also

offers a desired response when the system is subjected to various demands. The high adaptation speed along with high stability and performance

characteristics make this method a high quality control approach.

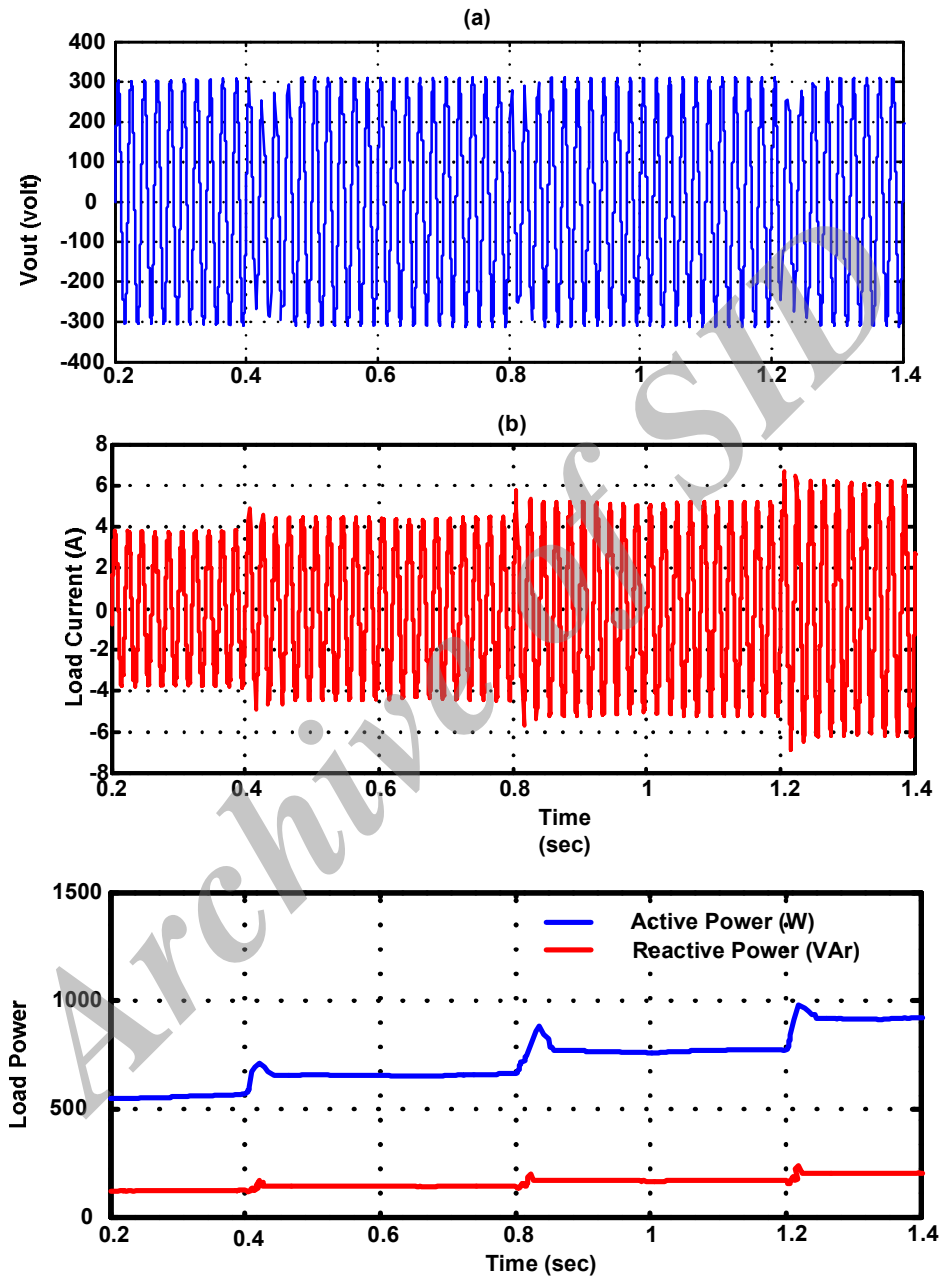

Fig.5. System response using a conventional PID controller

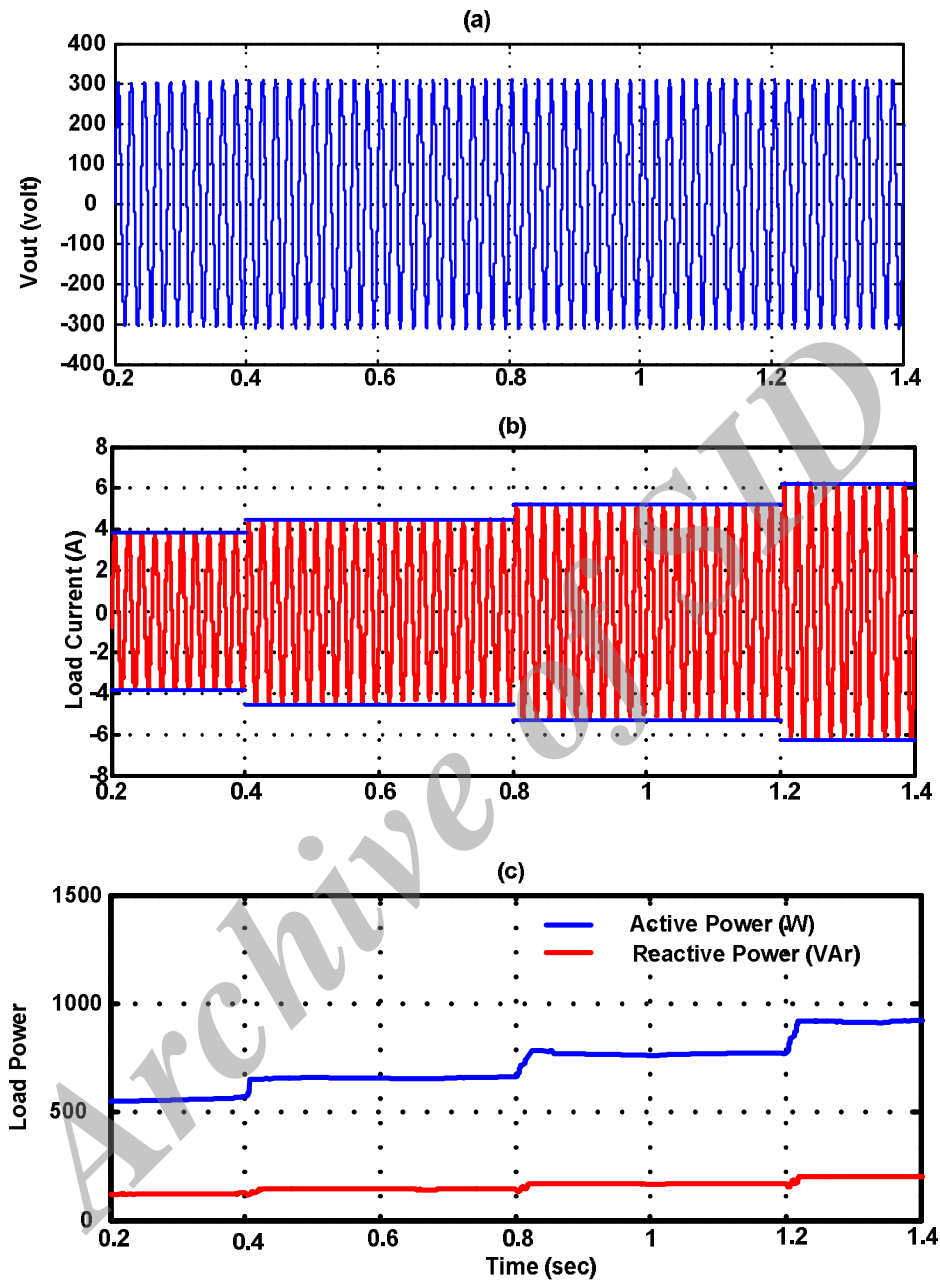

Fig. 6. System response using a conventional PID controller

REFERENCES

- [1] Jiayi H, Chuanwen J, Rong X. A review on distributed energy resources and MicroGrid. *Renewable and Sustainable Energy Reviews* 2008; 12: 2472–2483
- [2] Nikkhajoei H, Irvani R. Steady-State Model and Power Flow Analysis of Electronically-Coupled Distributed Resource Units. *IEEE Trans. Power Del* 2007; 22(1):721-728.

- [3] Sao CK, Lehn PW. Control and Power Management of Converter Fed Microgrids. *IEEE Trans. Power Systems* 2008;23(3):1088-1098.
- [4] Chen CL et al. Design of Parallel Inverters for Smooth Mode Transfer Microgrid Applications. *IEEE Trans. Power Electron* 2010;25(1):6-15.
- [5] Karimi H, Nikkhajoei H, Iravani R. Control of an Electronically-Coupled Distributed Resource Unit Subsequent to an Islanding Event. *IEEE Trans. Power Del* 2008;23(1):493-501.
- [6] Katiraei F, Iravani MR, Lehn PW. Micro-Grid Autonomous Operation During and Subsequent to Islanding Process. *IEEE Trans. Power Del* 2005;20(1):248-257.
- [7] Katiraei F, Iravani MR. Power Management Strategies for a Microgrid with Multiple Distributed Generation Units. *IEEE Trans. Power Systems* 2006; 21(4):1821-1831.
- [8] Katiraei F, Iravani MR and Lehn PW. Small-signal dynamic model of a micro-grid including conventional and electronically interfaced distributed resources. *IET Gener. Transm. Distrib* 2007; 1(3): 369–378.
- [9] Cheng PT, Chen CA, Lee TL and Kuo SY. A Cooperative Imbalance Compensation Method for Distributed-Generation Interface Converters. *IEEE Trans. Ind. Appl* 2009;45(2):805-815
- [10] Yannis M, Magdalene M, Georgios D (2011). “Honey bees mating optimization algorithm for the Euclidean traveling salesman problem,” *Infor. Sci.* 181(20):4684–4698
- [11] Niknam T (2011). An efficient multi-objective HBMO algorithm for distribution feeder reconfiguration. *Expert Syst. Appl.* 38(3):2878–2887
- [12] Noradin Ghadimi. PI Controller Design for Photovoltaic Systems in Islanding Mode Operation. *World Applied Sciences Journal* 15 (3): 326-330, 2011

SID



سرویس های ویژه



سرویس ترجمه تخصصی



کارگاه های آموزشی



بلاگ مرکز اطلاعات علمی



عضویت در خبرنامه



فیلم های آموزشی

کارگاه های آموزشی مرکز اطلاعات علمی جهاد دانشگاهی



کارگاه آنلاین آشنایی با پایگاه های اطلاعات علمی بین المللی و ترند های جستجو

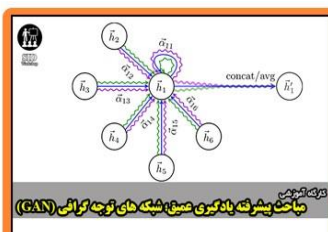

مباحث پیشرفته یادگیری عمیق؛ شبکه های توجه گرافی (Graph Attention Networks)



کارگاه آنلاین مقاله نویسی IEEE و ISI ویژه فنی و مهندسی