

# SID



سرویس های ویژه



سرویس ترجمه تخصصی



کارگاه های آموزشی



بلاگ مرکز اطلاعات علمی



سامانه ویراستاری STES



فیلم های آموزشی

## کارگاه های آموزشی مرکز اطلاعات علمی



مقاله نویسی علوم انسانی



اصول تنظیم قراردادها



آموزش مهارت های کاربردی در تدوین و چاپ مقاله

# Multiarea Transmission Cost Allocation in Large Power Systems Using the Nodal Pricing Control Approach

M. Ghayeni\* and R. Ghazi\*

**Abstract:** This paper proposes an algorithm for transmission cost allocation (TCA) in a large power system based on nodal pricing approach with multiarea scheme. The nodal pricing approach is introduced to allocate the transmission costs using the nodal pricing control in a single area network. As the number of equations is dependent on the number of buses and generators, this method will be very time consuming for large power systems. To solve this problem, the present paper proposes a new algorithm based on multiarea approach for regulating the nodal prices, so that the simulation time is greatly reduced and therefore the nodal pricing approach can be applicable for large power systems. In addition, in the proposed method, the transmission costs are allocated to the users more equitable than the single area method. Since the higher transmission costs of an area due to its higher reliability are paid only by users of that area in contrast with the single area method, in which these costs are allocated to all users regardless of their locations. The proposed method was implemented on the IEEE 118 bus test system having three areas. The obtained results show that with the application of multiarea approach, the simulation time is greatly reduced and the transmission costs are also allocated to users with less variation in new nodal prices with respect to the single area approach.

**Keywords:** Transmission Cost Allocation, Nodal Prices, Large Power Systems, Multiarea Approach.

## 1 Introduction

The nodal pricing approach for transmission cost allocation is currently developed worldwide. In this approach the network revenues are equal to the transmission rent (TR) and defined as the difference between what the loads pay and what the generators are paid. If the TR is calculated by locational marginal prices (LMPs), it will be termed as the marginal TR. Marginal pricing is in fact, a nodal pricing which is based on the LMPs and provides the correct economic signals to loads, generators and system operators towards the efficient use of the transmission network. Here, the main concern is that the obtained marginal TR cannot recover the total transmission network costs (TNC). In a special case of lossless network with no transmission congestion, LMPs at all buses are equal and so the marginal TR becomes zero. However, even for a lossy network under transmission congestion, there

is no guarantee that the marginal TR could recover the TNC [1].

To solve this problem, two approaches have been introduced. In the first approach, the marginal pricing is performed and then the uncovered costs, i. e. the difference between the TNC and marginal TR, as a complementary cost, is allocated to network users in terms of their extent of use of the network. Rubio-Oderiz and Arriaga have used this approach to allocate the complementary costs using both the participation factor and the benefit factor methods [2]. Sedaghati has defined the critical capacity and then allocated the complementary costs by using the modified benefit factor method [3]. Guo et al. have used the power tracing method to allocate the complementary costs to network users [4].

In the second approach, LMPs can be adjusted to the new nodal prices (NNPs) in such a way that the new obtained TR could recover the TNC. In Ref. [5] a comprehensive evaluation has carried out regarding this approach. In this reference the nodal prices are controlled to the new prices such that the TR becomes equal to the TNC and at the same time the sum of price deviations from marginal prices is minimized. In this method, the generator and load in each bus are cleared

---

Iranian Journal of Electrical & Electronic Engineering, 2010.

Paper first received 10 Aug. 2010 and in revised form 18 Sept. 2010.

\* The authors are with the Department of Electrical Engineering, Ferdowsi University of Mashhad, Mashhad, Iran.

E-mails: [mo\\_gh82@stu-mail.um.ac.ir](mailto:mo_gh82@stu-mail.um.ac.ir), [rghazi@um.ac.ir](mailto:rghazi@um.ac.ir).

with the same price. So, at those buses in which the NNP is less than the LMP, loads pay less and therefore receive a credit and at those buses the NNP is greater than the LMP, generators are paid more and so receive credit. This cannot be fair to all market participants since some transmission users get credit instead of paying charge, accordingly, these credits will impose extra charge on some users leading to more deviation of NNPs from LMPs. Furthermore, in this reference the share of loads and generators in TNC is tested only for 50 percent, while it does not work properly when the requested share is close to zero or hundred percent.

To solve these problems, the authors of present paper have introduced a new formulation for TR in [6], so that the generator and load in each bus are cleared with different prices regarding the direction of their injected power. If the injected power is positive, the generator is cleared by a new price rather than the LMP whereas the load will pay the price based on the LMP. On the other hand, if the injected power is negative, the clearing price of load is regulated to the new price but the generator is cleared by LMP. By considering this modification, those users have a contribution in reducing the network flows (loads in the positive injected buses and generators in the negative injected buses), instead of receiving a credit, do not pay the transmission costs and thereby the appropriate economic signals are provided. Therefore, this could lead to less variation in new prices than the method of Ref. [5]. The other advantage of this method is its flexibility to control the cost splitting between loads and generators for any pre-specified ratio from zero to hundred percent.

However, the main drawback of these single area methods [5 and 6] is that they are very time consuming ones when dealing with large power systems as the number of constraints in optimization problem is greatly increased. The program may take several hours to be executed for such large power systems. Therefore, implementation of such methods for hourly TCA in case of large power systems is not feasible. To solve this problem, in the present paper an algorithm is proposed in which the multiarea framework is utilized to calculate the nodal prices, so it needs only several minutes to do the job for large power systems. Consequently, the nodal pricing approach can be applicable for large power systems as well.

There are some papers dealing with various problems using multiarea approaches. Yu and David have used the sensitivity factors and AC-OPF to allocate the transmission costs in an interconnected power system via multiarea framework [7]. Gil et al. have applied the equivalent bilateral exchange (EBE) method to allocate the transmission costs in a multiple interconnected regions or countries [8]. Arriaga has presented the regulatory principles of cross border tariffication in the European electricity transmission network [9]. There are also some papers associated with

the transmission loss allocation using the multiarea approaches. Silva and Costa have used the incremental transmission loss concept for allocating the electric losses to generators and loads, participating in multiple interconnected energy markets [10]. Bialek et al. have applied the modified tracing-based methodology for allocating the transmission losses due to cross-border trades [11]. Kazemi and Andami have used the Z-bus method to allocate the transmission losses in multiarea networks [12]. This approach was further developed in [13] using a new loss formula. Lima et al. have applied the EBE method to allocate the cost of transmission losses in a multimarket framework [14].

With reference to those papers tackling the TCA problem in multiarea framework it can be stated that none of them using the nodal pricing approach. In the present paper the multiarea approach is used to allocate the transmission costs by our developed nodal pricing method which is fully described in [6]. Therefore, solving the TCA problem for large power systems based on nodal pricing approach in a multiarea framework is our main contribution. Our algorithm is not only quite fast but it also provides further advantages as follows.

The proposed method allocates the transmission costs in an equitable manner in compare with the single area method. As some areas have a higher reliability, their transmission costs are also high and some others have a lower reliability so their costs will be less. Therefore, if the cost allocation is made using the single area framework, the higher costs of the high reliability areas are distributed among all users regardless of their locations. Hence, the problem arises is that some users in lower reliability areas tolerated some portion of costs corresponding to the reliability with no apparent benefit. But in multiarea framework, the transmission costs of each area are allocated only to the users of that given area so a more equitable allocation is provided.

Furthermore, with regard to the reliability and economic matters, most of the power systems are connected to the neighboring networks of different countries through tie lines, therefore, a large multiarea power system is created. In such cases the international operator (IO) should allocate the transmission costs in a multiarea framework, because the detailed information of each area is not available to IO owing to the different market autonomy.

The rest of the paper is organized as follows:

In section 2, the final step of formulation of the TCA for a single area is rewritten from [6]. Our proposed scheme to allocate the TNC in a multiarea approach is explained and formulated in section 3. The presented approach is applied to IEEE 118-bus test system as numerical example and results are shown in section 4. The conclusions are given in section 5.

## 2 Single Area Cost Allocation

In nodal pricing approach the network revenues are equal to the TR which is defined as the difference

between what the loads pay and what the generators are paid. The marginal TR which is based on the LMPs cannot recover the TNC. So the nodal prices must be changed from the marginal points to the new points, so that the recent TR becomes equal to the TNC. In this section the final formulation of Ref. [6] method for calculating the nodal prices in a single area network is presented. In this method, the nodal prices are changed from marginal prices so as the TR can recover the TNC provided that the price variations to be minimized and the cost splitting between loads and generators realized in a pre-specified ratio.

To calculate the NNPs, an optimization problem is defined in Ref. [6]. The objective function is to minimize the variation of the NNPs from LMPs expressed by (1). The NNPs are controlled so as the TR becomes equal to the TNC, subject to Eq. (2) as a constraint. The cost splitting between loads and generators is controlled in a pre-specified ratio. If the share of the loads in the TNC is considered as  $\alpha$  percent of the TNC, the NNPs must satisfy the Eq. (3) as well. The NNPs also must satisfy the Kuhn-Tucker conditions defined by the Eqs. (4)-(7).

$$\text{Min } \sqrt{\sum_{i=1}^{N_b} (\text{NNP}_i - \text{LMP}_i)^2} \quad (1)$$

Subject to:

$$\sum_{i=1}^{N_b} [(\text{NNP}_i \times P_{d_i} - \text{LMP}_i \times P_{g_i}^*) \times U(P_{d_i} - P_{g_i}^*) + (\text{LMP}_i \times P_{d_i} - \text{NNP}_i \times P_{g_i}^*) \times U(P_{g_i}^* - P_{d_i})] = \text{TNC} \quad (2)$$

$$\sum_{i=1}^{N_b} [(\text{NNP}_i - \text{LMP}_i) \times P_{d_i} \times U(P_{d_i} - P_{g_i}^*)] = (\text{TNC} - \text{MTR}) \times \frac{\alpha}{100} \quad (3)$$

$$\text{IC}_{g_i}^* + \rho_{g_i} - \text{NNP}_i - \sigma_{L_i} + \sigma_{U_i} = 0 \quad i = 1, 2, \dots, N_g \quad (4)$$

$$\sum_{i=1}^{N_b} [(\rho_{\delta_i} + \text{NNP}_i) \times B_{ij}] + \sum_{l=1}^{N_l} [(\gamma_{U_l} - \gamma_{L_l}) \times H_{lj}] = 0 \quad \text{for } j = 1, 2, \dots, N_b \quad (5)$$

$$\sum_{i=1}^{N_g} \sigma_{L_i} \times (P_{g_i}^* - P_{g_i}^{\min}) + \sum_{i=1}^{N_g} \sigma_{U_i} \times (P_{g_i}^{\max} - P_{g_i}^*) + \sum_{l=1}^{N_l} \gamma_{L_l} \times (P_l^* - P_l^{\min}) + \sum_{l=1}^{N_l} \gamma_{U_l} \times (P_l^{\max} - P_l^*) = 0 \quad (6)$$

$$\begin{cases} \sigma_{L_i} \geq 0, & \sigma_{U_i} \geq 0 & i = 1, 2, \dots, N_g \\ \gamma_{L_l} \geq 0, & \gamma_{U_l} \geq 0 & l = 1, 2, \dots, N_l \end{cases} \quad (7)$$

where the symbols in these equations are defined as follows:

LMP<sub>i</sub> and NNP<sub>i</sub> are the location marginal price and new nodal price at bus i respectively,  $P_{g_i}^*$  and  $P_{d_i}$  are the generation and consumption power at bus i,  $U(\cdot)$  is the unit step function, TNC is the total transmission network costs, MTR is the marginal transmission rent,  $N_b$ ,  $N_g$  and  $N_l$  are the number of buses, generators and lines respectively,  $\rho_{\delta_i}$  and  $\rho_{g_i}$  are the penalty factors for the injected power of bus i and the generation unit i respectively, B is the network susceptance matrix and H is the matrix relating the voltage angles to lines power flows,  $P_{g_i}^{\max}$  and  $P_{g_i}^{\min}$  are the generation limits of unit i and also  $P_l^{\max}$  and  $P_l^{\min}$  are the flow limits in line l and  $\sigma_{L_i}$ ,  $\sigma_{U_i}$ ,  $\gamma_{L_l}$  and  $\gamma_{U_l}$  are the Lagrange multipliers related to lower & upper limits for generation unit i and transmission line l respectively.

This non-linear optimization problem is solved and the NNPs and other variables are found. After calculation of NNPs, the share of each generator and load in transmission costs are determined by Eqs. (8) and (9) respectively.

$$\text{TCG}_i = (\text{LMP}_i - \text{NNP}_i) \times P_{g_i}^* \times U(P_{g_i}^* - P_{d_i}) \quad (8)$$

$$\text{TCL}_i = (\text{NNP}_i - \text{LMP}_i) \times P_{d_i} \times U(P_{d_i} - P_{g_i}^*) \quad (9)$$

where  $\text{TCG}_i$  and  $\text{TCL}_i$  are the share of generator and load at bus i in TNC respectively.

It is clear that, for those buses in which the price is increased, the generators are cleared based on LMPs and so do not pay any costs for transmission, while the corresponding loads pay the transmission costs proportional to the increment of price in those buses. Similarly, for buses in which the price is decreased, the loads are cleared with the LMPs and do not pay the transmission costs while the corresponding generators pay for transmission costs proportional to the decrement of price in those buses.

In this method, the number of constraints is dependent on the number of buses and generators. Therefore, in large power systems, the number of constraints is too much and the solution needs long computation time. To solve this drawback, the present paper proposes the use of the multiarea framework to calculate the nodal prices which will be explained in the next section.

### 3 The Proposed Algorithm to Regulate the Nodal Prices using the Multiarea Approach

In this section our proposed method for regulating the nodal prices to allocate the transmission costs is explained in detail. By considering the multiarea system, at first, each tie-line is modeled by a virtual generator and a load at the boundary buses to balance the power in these buses. Therefore, the areas are decoupled from each other, and the single area method is performed for each area to calculate the area nodal

prices (ANPs) so as the ANPs recover only the area transmission network costs (ATNC). Afterwards, the interarea transmission costs (IATC) are determined and allocated to each area using the equivalent network which comprises boundary buses and tie-lines i. e. the all other lines connected to the boundary buses are replaced by virtual loads and generators. This allocated cost can be defined as area sharing in interarea transmission costs (AS-IATC). Finally, the single area method is used again in each area to calculate the final nodal prices (FNPs) to recover the sum of ATNC and AS-IATC of that area. Now at each bus, the share of each generator and load in transmission costs can be calculated based on the difference between the LMPs and FNPs. Fig. 1 shows the flowchart of our proposed method. Referring to this flowchart the procedure of our method comprises the following steps.

**Step1-** Run the optimal power flow for whole system and determine the power of generators and lines and also the LMPs.

**Step2-** Calculate the ATNC in each area and also the tie-lines cost (TLC).

**Step3-** Model the tie-lines by virtual generators and loads at boundary buses to balance the power in these buses.

**Step4-** Run the single area method for each area separately and calculate the ANPs to recover only the ATNC of that area. (In this step the TLC are not included).

**Step5-** Determine tie-lines sharing in ATNC (TLS-ATNC) and then add it to TLC to determine the IATC.

**Step6-** Make the equivalent network consists of tie-lines and boundary buses. Other lines connected to the boundary buses are modeled with virtual generators and loads.

**Step7-** Run the single area method for equivalent network and determine the AS-IATC.

**Step8-** Run the single area method again for each area to regulate the nodal prices from ANPs to the FNPs to recover the sum of ATNC and AS-IATC.

**Step9-** Calculate the share of each generator and load in transmission costs proportional to the change of their nodal prices from LMP to the FNP.

These steps are further elaborated in the rest of this section.

### 3.1 Optimal Power Flow

The transmission cost allocation is performed after clearance of the energy market. So, the market output including the generators and lines powers and the LMPs are the input data for TCA problem. Therefore, it is necessary at first to run the OPF for entire network so as to obtain these data by considering the generators bid and the network constraints. Then the marginal transmission rent (MTR) which is the difference between what the loads pay and what the generators are paid based on the LMPs, is calculated. According to the previous studies in this context, the MTR recovers only

a portion of transmission costs. Therefore, as our intention is to perform TCA by the nodal pricing approach, the nodal prices must be changed from the marginal points to the new points, so that the TR at current points becomes equal to the TNC.

### 3.2 Transmission Costs Calculation

The other input data for TCA problem is the value of transmission costs. The procedure of its calculation is explained in this stage. Suppose that the entire network is composed of several areas, connected by tie-lines.

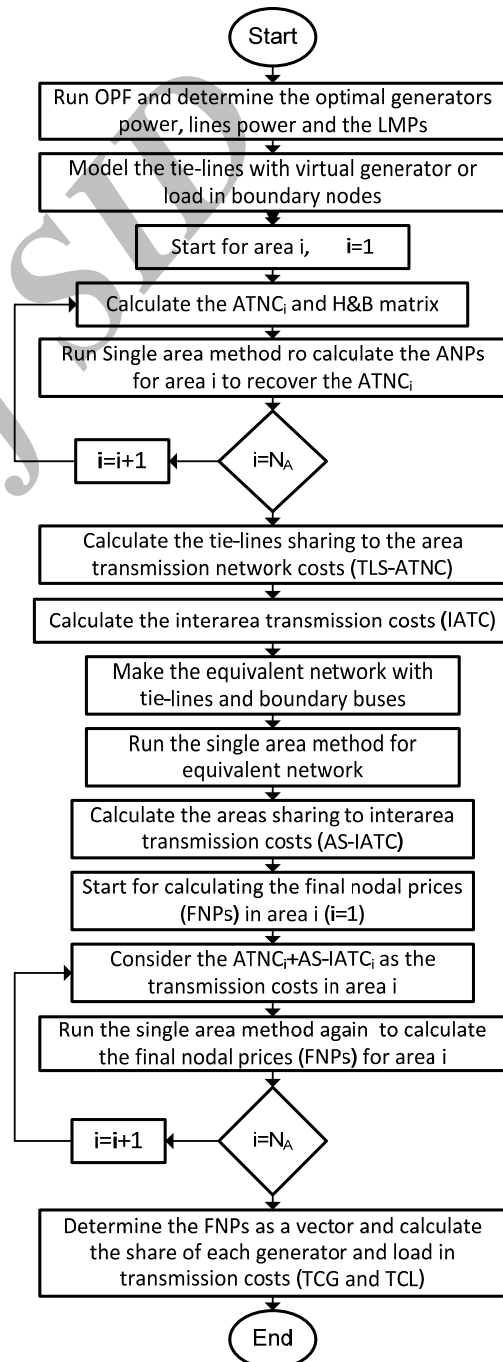

Fig. 1 Flowchart of the proposed method.

Each area can be a country, an RTO, or a traditional control area. Then the transmission network costs of each area (ATNC) and the tie-lines costs (TLC) are computed. The ATNC of each area consists of the lines cost, substations cost and operation cost of the network in that area. The lines cost (LC) is proportional to the capital and operation costs which in turn dependent on line length, voltage level, and its capacity as formulated in (10). The substation is treated as a line with unit length connected between high and low voltage buses.

$$LC_1 = LC_1^{pu} \times C_1 \times L_1 \quad (10)$$

where,  $LC_1^{pu}$  is cost of line l having unit length and capacity for one hour,  $C_1$  and  $L_1$  are the capacity and length of line l respectively.  $LC_1$  is the total cost of line l for each hour.

The ATNC is calculated by adding the area system cost (ASC) which is related to the operating cost of network to the sum of lines costs using (11).

$$ATNC_i = \sum_{l=1}^{N_{li}} LC_l + ASC_i \quad i = 1, 2, \dots, N_A \quad (11)$$

where,  $N_{li}$  is the number of lines in area i,  $ASC_i$  is the system cost of area i.  $N_A$  is the number of areas. The tie-lines cost (TLC) is the sum of individual tie line cost:

$$TLC = \sum_{t_1=1}^{N_{t_1}} TLC_{t_1} \quad (12)$$

where  $TLC_{t_1}$  is the cost of tie-line  $t_1$ , and  $N_{t_1}$  is the number of tie-lines.

### 3.3 Decouple the Areas

In order to implement the single area method in each area, the areas must be decoupled from each other. To do so the tie-lines are modeled by virtual generators and loads at boundary buses. If the power is extracted from area (exporting tie-line) the tie-line modeled by a virtual load at boundary bus and if it is injected into area (importing tie-line) modeled by a virtual generator at boundary bus as shown in Fig. 2.

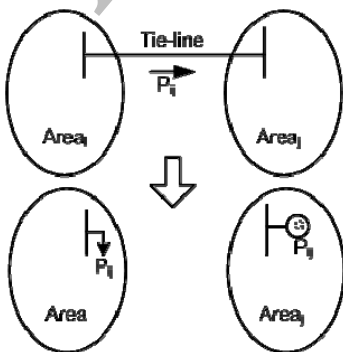

Fig. 2 Power balance at boundary buses.

This figure shows a tie-line connected between areas i and j in which the power is transmitted from area i towards area j so, the link is replaced by a virtual load at boundary bus of area i and virtual generator at boundary bus of area j.

### 3.4 Area nodal Prices

At first, the MTR and some other required information such as H and B matrices are determined for all areas. Then, the single area method of section 2 is run for each area separately to calculate the area nodal prices (ANPs) so that the results obtained from these prices could recover the ATNC and also control the share of loads in this cost with any arbitrary value say  $\alpha$  percent.

### 3.5 Interarea Transmission Costs

It should be noted that some of the ATNC in each area are associated with the tie-lines which are modeled by virtual loads and generators. These costs arise from this fact that the tie-lines utilize the areas network for transmitting power between areas. So the interarea transmission costs (IATC) have two parts, one part reflecting the tie-line costs (TLC) itself and the other part corresponds to tie-lines sharing in area transmission network costs (TLS-ATNC). The former costs are obtained from Eq. (12) and the latter costs from Eq. (13) in which the share of each tie-line is determined by price variations from LMP to ANP at boundary buses as follows.

$$TLS - ATNC_{t_1} = (\text{ANP}_{t_1}^{\text{from}} - \text{LMP}_{t_1}^{\text{from}}) \times P_{t_1}^{\text{from}} \times U(P_{t_1}^{\text{from}}) + (\text{LMP}_{t_1}^{\text{to}} - \text{ANP}_{t_1}^{\text{to}}) \times P_{t_1}^{\text{to}} \times U(P_{t_1}^{\text{to}}) \quad (13)$$

where  $P_{t_1}^{\text{from}}$  and  $P_{t_1}^{\text{to}}$  are the sending and receiving power in tie-line  $t_1$  respectively and  $P_{t_1}^{\text{from}}$  and  $P_{t_1}^{\text{to}}$  are the injection power at the sending and receiving boundary buses respectively.

The interarea transmission costs (IATC) is calculated by sum this cost for all tie-lines and add it to original tie-lines costs:

$$IATC = \sum_{t_1=1}^{N_{t_1}} TLS - ATNC_{t_1} + TLC \quad (14)$$

### 3.6 Tie-Lines Equivalent Network

To calculate the share of each area in IATC, the single area equivalent network comprising only the tie-lines is needed. In [13] each area is modeled by an equivalent bus. For example, a three-area system is substituted by a network having three equivalent buses. However, in special situations this equivalent network will arise some errors. For instance, when two areas are connected by several tie-lines in which the power flow in every tie-line is high but the net exchange power between two areas is low. In such cases for obtaining better results each area is modeled by equivalent buses

instead of a single equivalent bus. The number of equivalent buses is equal to the number of boundary buses. To balance the power at these buses, every transmission line in each area which is connected to boundary buses is modeled as a virtual generator and a load similar to what quoted in section 3.3.

### 3.7 Areas Sharing in IATC

The matrices H and B of the above equivalent network are calculated and then the single area method is run to calculate the new prices at boundary buses to recover the IATC. The share of each boundary bus in IATC is determined using its price variation. Now the area sharing in interarea transmission costs (AS-IATC) is determined by adding the share of all boundary buses of that area.

### 3.8 Final Nodal Prices

Now, the ANPs which were calculated in section 3-4 for recovering the ATNC, should be controlled to the final nodal prices (FNPs) so that the transmission rent of each area can recover the total cost of ATNC and AS-IATC in that area. To do this, the single area method is run again for each area but at this time the prices are changed from ANPs to FNPs to recover the total costs associated with that area. These FNPs are able to recover all the transmission network costs.

### 3.9 Share of Generators and Loads in Transmission Costs

At final step, the share of each generator and load in transmission network costs can be calculated based on the price variations from LMPs to FNPs using Eqs. (8) and (9). As was mentioned in section 2, those generators or loads helping reduce the network usage do not pay the transmission cost. If the FNP of a bus is less than its LMP, the load cleared with LMP and therefore does not pay any transmission cost and the generator at that bus will pay the transmission costs proportional to the rate of price reduction. Similarly, if the FNP of a bus is greater than its LMP, the generator is paid by LMP so does not pay any costs and the load is charged for transmission costs based on the price increasing.

## 4 Simulation Results

Our proposed method is implemented on a three-area IEEE 118-bus test system as shown in Fig. 3 [15]. This network comprises two voltage levels, 345kV with 12 buses and 11 lines and 138kV with 106 buses and 166 lines, as connected together via 9 transformers. This system has also 54 generation units [16]. The brief information of each area is presented in Table 1.

At first, the OPF is run for all network and the power of generators, flow of lines, and LMP of buses are determined. The LMPs are varied between \$36.54 and \$41.25 where the maximum LMP is at bus 41 and minimum LMP is at bus 89. Then the cost of each line

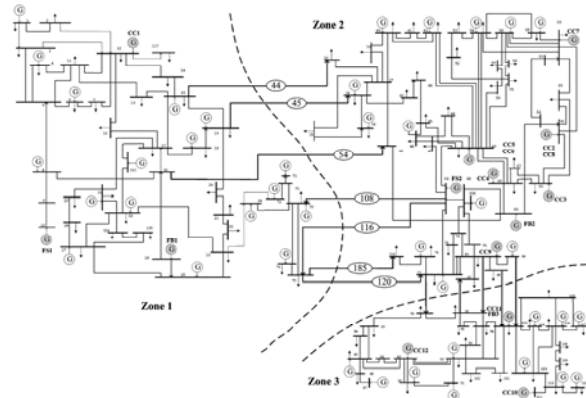

Fig. 3 Single line diagram of three-area IEEE 118-bus test system.

Table 1 Brief information of 118 bus test system.

Area	TNC (\$/h)	Index	No.	Capacity Lines and trans.: MVA		
				Gen. and load : MW		
				Total	Min	Max
Area1	3375.9	345kv Lines	4	1600	100	1500
		138kv Lines	53	7000	100	500
		transformer	3	1500	500	500
		generators	20	1850	20	500
		loads	35	1175	6	90
Area2	5404.8	345kv Lines	5	2500	500	500
		138kv Lines	63	8700	100	500
		transformer	7	3500	500	500
		generators	20	3680	30	500
		loads	39	2163	12	277
Area3	1876.2	345kv Lines	0	0	0	0
		138kv Lines	42	7400	100	500
		transformer	0	0	0	0
		generators	14	2340	20	650
		Loads	25	904	2	163
Tie-lines	605.11	345kv Lines	1	100	100	100
		138kv Lines	11	1900	100	500
Sum	11262					

is computed using Eq. (10) and the ATNC of each area is calculated by Eq. (11). The ATNC in area1 is \$3375.9/h whereas for area2 and area3 are \$5404.8/h and \$1876.2/h respectively. Also the tie-lines cost is calculated by Eq. (12) which is equal to \$605.11/h so, the TNC of entire network is \$11262/h.

For implementation of our method to determine the new prices in each area, it is necessary to make the power balance at boundary buses. In this test system, there are 3 areas connected to each other through 12 tie-lines with 18 boundary buses. Fig. 4 shows the magnitude (in MW) and the direction of power flow in

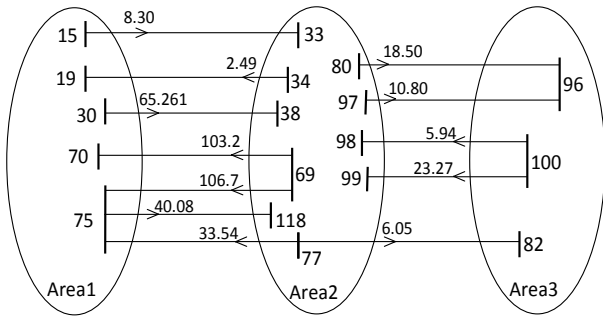

Fig. 4 Magnitude of power flow (MW) in tie-lines.

tie-lines. These tie-lines are modeled as virtual loads and generators at boundary buses. For example, the tie-line between buses 15 and 33 is modeled by a virtual load at bus 15 having 8.30 MW and a virtual generator at bus 33 having 8.27 MW. The difference between these values arises from power losses of the given tie-line.

Now, the single area method of section 2 is run for each area separately. So the ANPs are calculated for each area so that the TR obtained from these prices recovers the ATNC of that area. The cost splitting between loads and generators can be controlled in a pre-specified ratio  $\alpha$ . The results for  $\alpha=50\%$ , i. e. the equal cost splitting between loads and generators, are reported. The ANPs are plotted for three areas in Figs. 5-7.

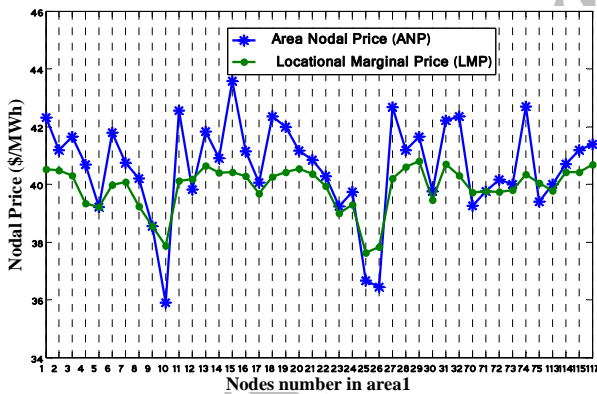

Fig. 5 The ANPs of area 1.

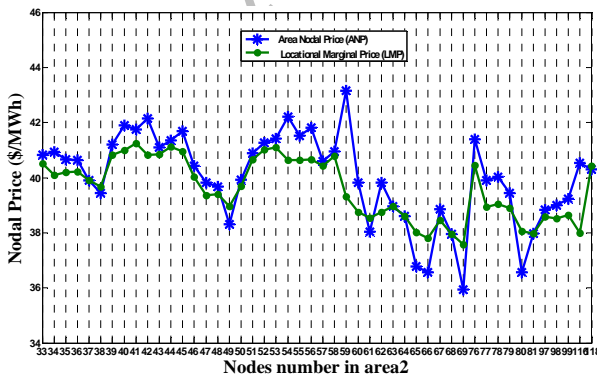

Fig. 6 The ANPs of area 2.

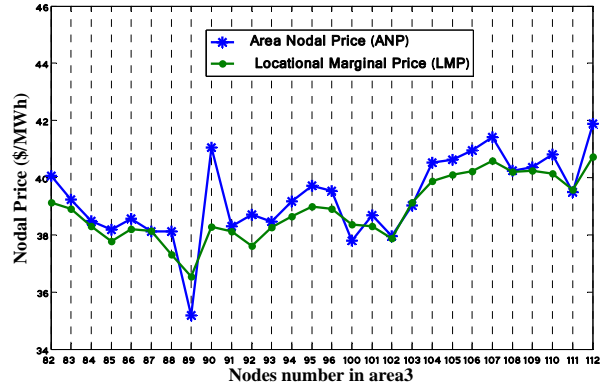

Fig. 7 The ANPs of area 3.

Also, Table 2 shows the statistical information regarding these ANPs. The maximum ANP corresponds to bus 15 at area1 with \$43.58/MWh and the minimum ANP is \$35.19/MWh at bus 89 in area3. Also the standard deviation (STD) of ANPs is low in area3 with amount of 1.41 and high in area1 with amount of 1.66.

The tie-lines which are modeled as fictitious loads or generators placed at boundary buses, have \$243/h sharing in total ATNC. These sharing can be shown in details in last column of Table 2.

Now, the share of each area in IATC is computed. The IATC consists of two parts, the TLC \$605.11/h and the TLS-ATNC with amount of \$243/h. So the IATC is equal to \$848.08. This cost is allocated to areas using the 18 bus equivalent network (boundary buses and tie-lines) and the results are presented in Table 3.

Finally, the single area method is applied for considering the total area cost of that area as defined in Table 3. Therefore, the obtained FNPs are such that the total transmission costs in each area are recovered. Fig. 8 shows the FNPs for all buses of the network. The maximum and minimum of FNPs are \$43.695/MWh and \$35.13/MWh respectively.

Table 2 The statistical information of area nodal prices.

Area	ANP (\$/MWh)			Area TR (\$/h)	TLS-ATNC (\$/h)
	Max	Min	STD		
Area1	43.58	35.90	1.66	3194.2	181.7
Area2	43.16	35.95	1.62	5349.1	55.7
Area3	41.88	35.19	1.41	1870.6	5.6
Sum	-----	-----	-----	10413.8	243

Table 3 Contribution of areas in IATC.

Costs	Area 1	Area 2	Area 3
AS- IATC (\$/h)	170.43	626.22	68.68
ATNC (\$/h)	3375.86	5404.77	1876.19
Sum Cost (\$/h)	3546.29	6030.99	1944.87



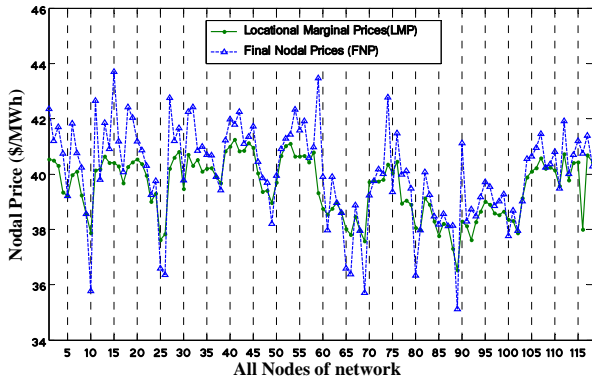

Fig. 8 The final nodal price in all buses of network.

Contribution of each load and generator in transmission costs is computed using Eqs. (8) and (9) respectively. Table 4 shows these contributions for some buses (only the first twenty and the last ten are shown because space limitation).

Table 4 Contribution of loads and generators in transmission costs for some buses.

Bus No.	$P_d$ MW	$P_g$ MW	LMP	NNP	TCG	TCL
1	51	0	40.53	42.36	0	93.57
2	20	----	40.49	41.21	-----	14.40
3	39	----	40.30	41.71	-----	54.72
4	39	0	39.33	40.74	0	54.72
5	-----	-----	39.22	39.22	-----	-----
6	52	0	39.97	41.84	0	97.28
7	19	----	40.09	40.77	-----	13.00
8	28	0	39.23	40.24	0	28.21
9	-----	-----	38.55	38.55	-----	-----
10	----	436	37.86	35.77	911.8	-----
11	70	-----	40.13	42.65	-----	176.2
12	47	82.4	40.19	39.79	32.47	0
13	43	6.78	40.64	41.86	0	41.58
14	14	-----	40.41	40.91	-----	7.06
15	90	0	40.42	43.70	0	295
16	25	----	40.29	41.19	-----	22.49
17	11	-----	39.67	40.07	-----	4.36
18	60	0	40.27	42.42	0	129.5
19	45	0	40.43	42.05	0	72.85
20	18	0	40.54	41.19	0	11.65
-----						
110	39	0	40.14	40.82	0	26.41
111	0	34.89	39.58	39.50	2.91	0
112	68	0	40.73	41.91	0	80.28
113	6	0	39.78	40.00	0	1.29
114	8	----	40.42	40.70	-----	2.30
115	22	----	40.42	41.21	-----	17.41
116	184	0	37.99	40.75	0	507.2
117	20	-----	40.68	41.40	-----	14.39
118	33	-----	40.44	40.29	-----	0
-----						
<b>Max</b>	<b>277</b>	<b>588.2</b>	<b>41.25</b>	<b>43.67</b>	<b>936.1</b>	<b>1150</b>
<b>Sum</b>	<b>4242</b>	<b>4319</b>	<b>-----</b>	<b>-----</b>	<b>5630</b>	<b>5630</b>

The highest contribution among producers corresponds to generator at bus 69 with \$936.12 and the highest contribution among consumers is \$1149.64 related to bus 59. Generators at buses 31, 46, 54 and 59 do not pay any transmission costs, since their productions are consumed locally. Also loads at buses 12, 49, 66, 70, 75, 80, 100, 103 and 118 are supplied locally and therefore they do not pay any transmission costs.

At final stage, a comparison is made between our multiarea proposed method with the single area methods of [5], [6]. For this purpose, the obtained results from all methods are reported along with the statistical indices in Table 5. It can be seen that, the simulation time in our method is considerably reduced. The simulation time is 11489s for Ref. [5] method and 11542s for Ref. [6] method whereas for our method is about 145.7s. Also, in our method the price variation is much lower than that of single area methods. The minimum FNP has increased from \$33.35/MWh and \$34.43/MWh to \$35.13/MWh and also the maximum FNP decreased from \$43.84/MWh and \$45.44/MWh to \$43.695/MWh regarding the single area methods and the multiarea method. The difference between Max and Min of FNPs in [5] is \$10.49/MWh and \$11.01/MWh in [6], while this index has decreased to \$8.57/MWh in our method, although the standard deviation of FNPs is slightly increased.

Statistical indices also show that the variation of FNPs in our method is less than that of single area methods. It means that the transmission costs are allocated to users with smoother variations in the nodal prices. If the share of generators or loads in transmission costs is compared, in the presented method the maximum share for generators decreased from \$1874/h and \$1235.6/h to \$936.124/h and for loads decreased from \$1252.5 and \$1696.7 to \$1149.64/h. The corresponding standard deviation is also decreased about 31.74 & 3.17 percent for generators and 9.55 & 25.64 percent for loads respectively.

Table 5 Comparison of our method and Refs. [5, 6] methods.

Statistical Indices	Ref [5] method	Ref [6] method	Proposed Method
Simulation Time (second)	11489	11542	140.75
Max FNP (\$/MWh)	43.84	45.44	43.695
Min FNP (\$/MWh)	33.35	34.43	35.128
Max FNP- Min FNP	10.49	11.01	8.567
STD FNP (\$/MWh)	1.669	1.636	1.699
Volatility%	4.17	4.09	4.240
Max TCG (\$/h)	1874	1235.6	936.124
STD TCG (\$/h)	258.3	182.10	176.32
Max TCL (\$/h)	1252.5	1696.7	1149.640
STD TCL (\$/h)	141.2	171.76	127.72

**Table 6** Contribution of each area from TNC.

Method	Users	The share of areas in TNC (\$/h)			
		Area1	Area2	Area3	Sum
Single area method [5]	Loads	1052	3530	1048	5630
	Generators	1737	1860	2033	5630
	Total	2789	5390	3081	11260
Single area method [6]	Loads	909	3808	912	5630
	Generators	1228.9	2026	1475	5630
	Total	2138	6735	2387	11260
Proposed multiarea method	Loads	1789	2906	934	5630
	Generators	1789	2906	934	5630
	Total	3579	5812	1869	11260

Also, the share of all loads and generators in each area is compared for all methods in Table 6. It is seen that in single area methods although the cost splitting between generators and loads for entire network has been done in accordance with predefined ratio (50/50 percent) but this splitting ratio is not observed in each area. For single area methods, in area 1 the loads pay 37.7 and 42.5 percent and generators pay 62.3 and 57.5 percent of costs, in area 2 loads have 65.5 and 56.6 percent contribution in transmission costs and these contributions are 34 and 38.2 percent in area 3. However, in multiarea method this cost splitting is controlled not only for entire system but also for each area as shown in Table 6.

In addition, by comparing the total payment made by loads and generators in each area it is found that the total payment by users in each area in multiarea method is very close to ATNC of that area but this is not valid in the single area methods. For example, the ATNC of area 3 is \$1876.2 but the total payment by loads and generators of this area in single area methods are \$3081.2 and \$2387.8 which are far from total costs. It means that the users of this area are tolerated some portion of transmission costs of other areas without receiving any apparent benefit. So, a more equitable allocation is provided by our proposed multiarea method in compare with the single area methods.

## 5 Conclusion

In this paper a multiarea approach based on controlling the nodal prices is proposed for TCA problem. This algorithm is quite fast so it can be easily applied for large power systems. The results show that the simulation time is greatly reduced when applied on a large power system. In addition, the proposed method allocates the transmission costs more equitable than the single area approaches. Since, in multiarea framework, the costs of each area are allocated to all users of that area. Therefore, if the ATNC of a given area is high, due to its higher reliability index, only the users of this area will contribute, whereas, in the single area methods

the costs of whole system allocated to all users regardless of their locations. Hence, in single area approaches the users of a given area with lower reliability, experiencing some excessive costs without benefiting from it. Results also show that in the proposed approach, the variations of nodal prices for recovering the transmission costs are smooth in compare with the single area methods.

## References

- [1] Arriaga I. J. P., Rubio F. J., Puerta J. F., Arceluz J. and Martín J., "Marginal pricing of transmission services: An analysis of cost recovery," *IEEE Trans. Power Syst.*, Vol. 10, No. 1, pp. 546-553, February 1995.
- [2] Rubio-Oderiz F. J. and Arriaga I. J. P., "Marginal pricing of transmission services: A comparative analysis of network cost allocation methods," *IEEE Trans. Power Syst.*, Vol. 15, No. 1, pp. 448-454, February 2000.
- [3] Sedaghati A., "Cost of Transmission System Usage Based on an Economic Measure," *IEEE Trans. Power Syst.*, Vol. 21, No. 2, pp. 446-473, May 2006.
- [4] Guo J., Wu Q. H., Turner D. R., Wu Z. X. and Zhou X. X., "Revenue Reconciliation for Spot Pricing: Implementation and Implication," *Elect. Power Compon. Syst.*, Vol. 32, No. 1, pp. 53-73, January 2004.
- [5] Gil H. A., Galiana F. D. and da Silva E. L., "Nodal price control: A mechanism for transmission network cost allocation," *IEEE Trans. Power Syst.*, Vol. 21, No. 1, pp. 3-10, February 2006.
- [6] Ghayeni M. and Ghazi R., "Transmission Cost Allocation in Restructured Power Systems Based on Nodal Pricing Approach by Controlling the Marginal Prices," *Iranian Journal of Electrical & Electronic Engineering*, Vol. 6, No. 2, pp. 93-102, June 2010.
- [7] Yu C. W. and David A. K., "Transmission cost allocation in multi-area power pool operation," *IEE Conf. Power Syst. Control and management*, pp. 52-57, 1996.
- [8] Gil H. A., Galiana F. D. and Conejo A. J., "Multiarea transmission network cost allocation," *IEEE Trans. Power Syst.*, Vol. 20, No. 3, pp. 1293-1301, Aug. 2005.
- [9] Arriaga I. J. P., "Cross-border tariffication in the internal electricity market of the European union," *Proc. 14th PSCC*, pp. 1-9, Sevilla, Spain, Jun. 2002.
- [10] Da Silva A. M. L. and De Carvalho Costa J. G., "Transmission loss allocation. Part II. Multiple interconnected energy markets," *IEEE Trans. Power Syst.*, Vol. 18, No. 4, pp. 1395-1401, Nov. 2003.

- [11] Bialek J. W., Ziemianek S. and Wallace R. A., "Methodology for allocating transmission losses due to cross-border trades," *IEEE Trans. Power Syst.*, Vol. 19, No. 3, pp. 1255-1262, 2004.
- [12] Kazemi A. and Andami H., "Multi-area Power System Loss Allocation Using Z-bus Method," *First International Power and Energy Conference*, Malaysia, November 28-29, 2006.
- [13] Kazemi A. and Andami H., "Introducing a New Method for Multiarea Transmission Networks Loss Allocation," *Iranian Journal of Electrical & Electronic Engineering*, Vol. 3, No. 1&2, pp. 21-30, Jan. 2007.
- [14] Lima D. A., Conejo A. J. and Contreras J., "Allocation of the cost of transmission losses in a multimarket framework," *IEE Proc.-Gener. Transm. Distrib.*, Vol. 153, No. 6, pp. 670-676, Nov. 2006.
- [15] Lu B. and Shahidehpour M., "Unit Commitment With Flexible Generating Units," *IEEE Trans. Power Syst.*, Vol. 20, No. 2, pp. 1022-1034, May 2005.
- [16] Christie R., University of Washington, Available at: <http://www.ee.washington.edu/research/pstca/>.



**Mohsen Ghayeni** was born in Mashhad, Iran in 1980. He received the B.Sc. degree in electronic engineering and the M.Sc. degree in power engineering both from Ferdowsi University of Mashhad, Iran, in 2002 and 2006 respectively. He is currently a Ph.D. student at the Ferdowsi University of Mashhad. His research interests are power system operation, power market and power quality.



**Reza Ghazi** (M'90) was born in Semnan, Iran in 1952. He received his B.Sc., degree (with honors) from Tehran University of Science and Technology, Tehran, Iran in 1976. In 1986 he received his M.Sc degree from Manchester University, Institute of Science and Technology (UMIST) and the Ph.D. degree in 1989 from University of Salford UK, all in electrical engineering. Following receipt of the Ph.D. degree, he joined the faculty of engineering Ferdowsi University of Mashhad, Iran as an Assistant Professor of electrical engineering. He is currently Professor of Electrical Engineering in Ferdowsi University of Mashhad, Iran. His main research interests are reactive power control, FACTS devices, application of power electronic in power systems, distributed generation, restructured power systems control and analysis. He has published over 90 papers in these fields including three books.

Archive

# SID



سرویس های ویژه



سرویس ترجمه تخصصی



کارگاه های آموزشی



بلاگ مرکز اطلاعات علمی



سامانه ویراستاری STES



فیلم های آموزشی

## کارگاه های آموزشی مرکز اطلاعات علمی



مقاله نویسی علوم انسانی



اصول تنظیم قراردادها



آموزش مهارت های کاربردی در تدوین و چاپ مقاله