

SID



سرویس های ویژه



سرویس ترجمه تخصصی



کارگاه های آموزشی



بلاگ مرکز اطلاعات علمی



عضویت در خبرنامه



فیلم های آموزشی

کارگاه های آموزشی مرکز اطلاعات علمی جهاد دانشگاهی



کارگاه آنلاین کاربرد نرم افزار SPSS در پژوهش

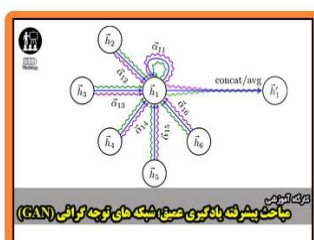

مباحث پیشرفته یادگیری عمیق؛ شبکه های توجه گرافی (Graph Attention Networks)



کارگاه آنلاین مقاله نویسی ISI و IEEE و ژورنال فنی و مهندسی



A New Optical Implementation of Reversible Fulladder Using Optoelectronics Devices

Mohsen Afshar[✉], Hamidreza Hoseini

Electronic Department, Arak Branch, Islamic Azad University, Arak, Iran
mafshar123@yahoo.com; hr-hoseiny@iau-arak.ac.ir

Received: 2011/12/25; Accepted: 2012/01/19

Abstract

This study introduces a reversible optical fulladder. Also optical NOT and NOR gates are implemented through Electro-Absorption-Modulator / Photo Detector (EAM/PD) pairs, were utilized for fulfilling reversible R gate. Then, reversible fulladder was designed based on the proposed reversible optical R gate. The operation of the suggested fulladder was simulated using Optispice and it was found that the delay time in comparison with VLSI implemented circuit has remarkably improved.

Keywords: *Optical Reversible Fulladder, Optical Reversible Gate, EAM/PD, Optical NOR, Gate, Optical NOT Gate*

1. Introduction

Optical logic gates came into vogue several decades to examine the possibility of achieving higher operating speeds than electronics based logic. Various optical logic gates have been designed up to now using optical elements like S-SEED and EAM/PD [1-2]. Sole bit fulladder which is a fundamental element in designing most of the computation circuits is implemented by SEED [3]. Optical fulladder has not been produced yet using EAM/PD. Therefore, this article aims at designing reversible optical fulladder using optical waveguide EAM/PD pair.

On the other hand, erasing bits of information during the logic operation brings about a significant amount of energy dissipation of conventional digital circuits. Thus, through designing logic gates in a way that the destruction of the information bits is avoided, the power consumption can be reduced dramatically [4]. Reversible computation can prevent losing bits of information which in turn has led to the development of reversible gates. Considering that reversible gates save outputs in a way, the number of electrooptical elements that are switched in optical circuits are reduced which in turn results in reduction of power dissipation in the circuits. Therefore, it was tried to add the property of reversibility to the proposed optical fulladder and design reversible optical fulladder using EAM/PD.

2. Full Adders

Among conventional fulladders, carry look-ahead adders (CLA) which achieve speed

through parallel carry computations, are the fastest of all adders. Figure 1 shows partial fulladder (PFA) based on the CLA logic [4]. CLA's output expressions are as follows:

$$C_{OUT} = C_{i+1} = G_i + P_i \cdot C_i \quad (1)$$

$$\text{Where, } G_i = A_i \cdot B_i \text{ and } P_i = A_i \oplus B_i$$

$$S_i = A_i \oplus B_i \oplus C_i = P_i \oplus C_i \quad (2)$$

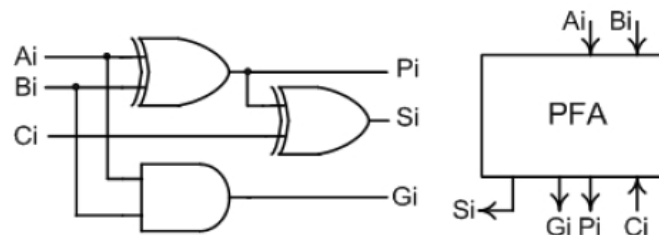

Figure 1. Partial Full Adder (PFA)

Reversible fulladder can be implemented with reversible gates such as Toffoli gate, the Fredkin gate, R gate and quite a few other reversible gates have been proposed over the years. In comparison with those using the Fredkin gate, the new R gate results in more efficient adders in relation to gate count and delay time[4]. As it can be seen in Figure 2, a reversible partial full adder requires only three R gates.

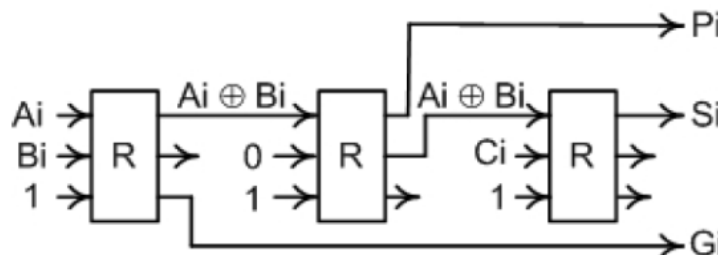

Figure 2. Partial Full Adder using R gates

3. Optical gates and devices

There are a lot of types of optical and opto-electronic devices such as couplers, waveguides, detectors, switches, lasers and so on which can be used for implementing logic circuits. Because of light and optical circuits advantage on speed and noise against conventional electronics implementations, optical and opto-electronic devices have been favored by scientists in recent years. So, we introduce some of this devices and circuits in this section.

3.1 EAM/PD

Electro-absorption modulators are a kind of optical switches which are controlled electrically. The light absorption of the device is changed by an applied electric field that directly controls the transmission of the optical data stream. These devices are typically reverse-biased p-i-n diodes. The intrinsic region of the given diodes is either bulk semiconductor, or made of multiple quantum wells. In the former case, the

absorption shift is due to the Franz-Keldysh effect, and in the latter one the quantum confined Stark effect (QCSE) provides the switching mechanism [5-6]. Some compound semiconductor substrates are used in the structure of electroabsorption modulator. The structure of the alloys composing the given modulator is such that the electroabsorption modulator can work with a laser set in wavelength range of 0.8-2.0 μm [1][5-6]. An illustration of the integrated photodiode-modulator structure is shown in figure 3(a), and figure 3(b) shows a simplified circuit diagram. The PD and EAM are detached by 50 μm .

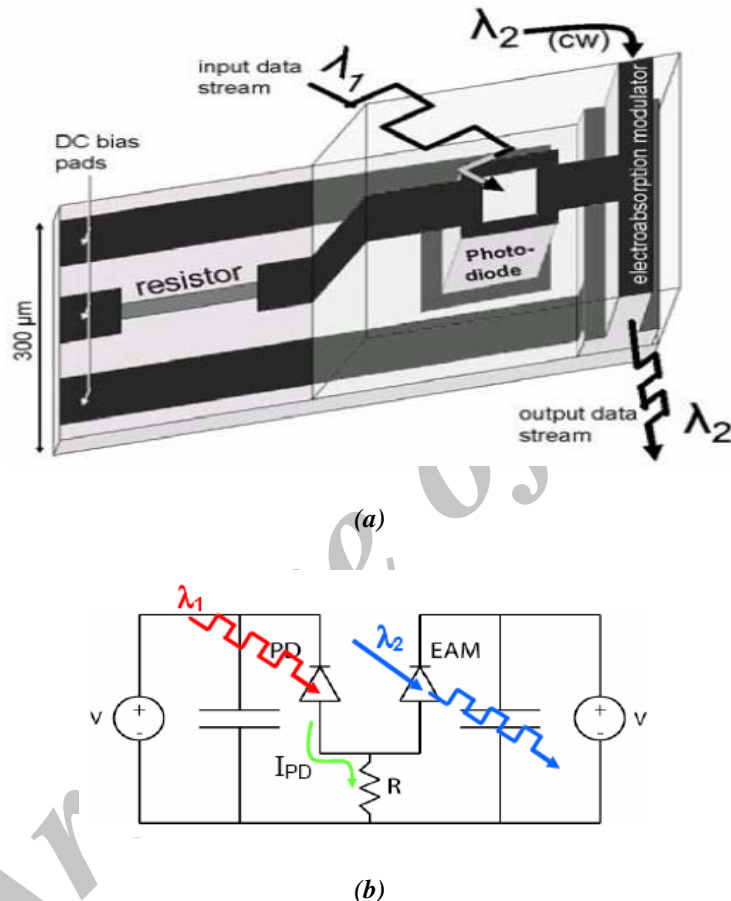

Figure 3. PD/EAM integrated photonic switch: (a) schematic view, (b) a simplified circuit diagram.

3.2 Optical 3-input NOR gate

Two pairs of optical waveguide devices consisting of an electro-absorption modulator electrically connected in series with a waveguide photodetector constitute an optical NOR gate [1]. Schematic diagram of the electrical and optical circuit for the proposed optical 3-input NOR gate is shown in figure 4. A laser located on the substrate can provide the light input. The laser operates in a wavelength range of 0.8-2.0 microns. In this figure, the laser of the continuous wave (CW-Source) has been set in wavelength of 800 nm and produces a continuous wave light with average optical power of 40 mw.

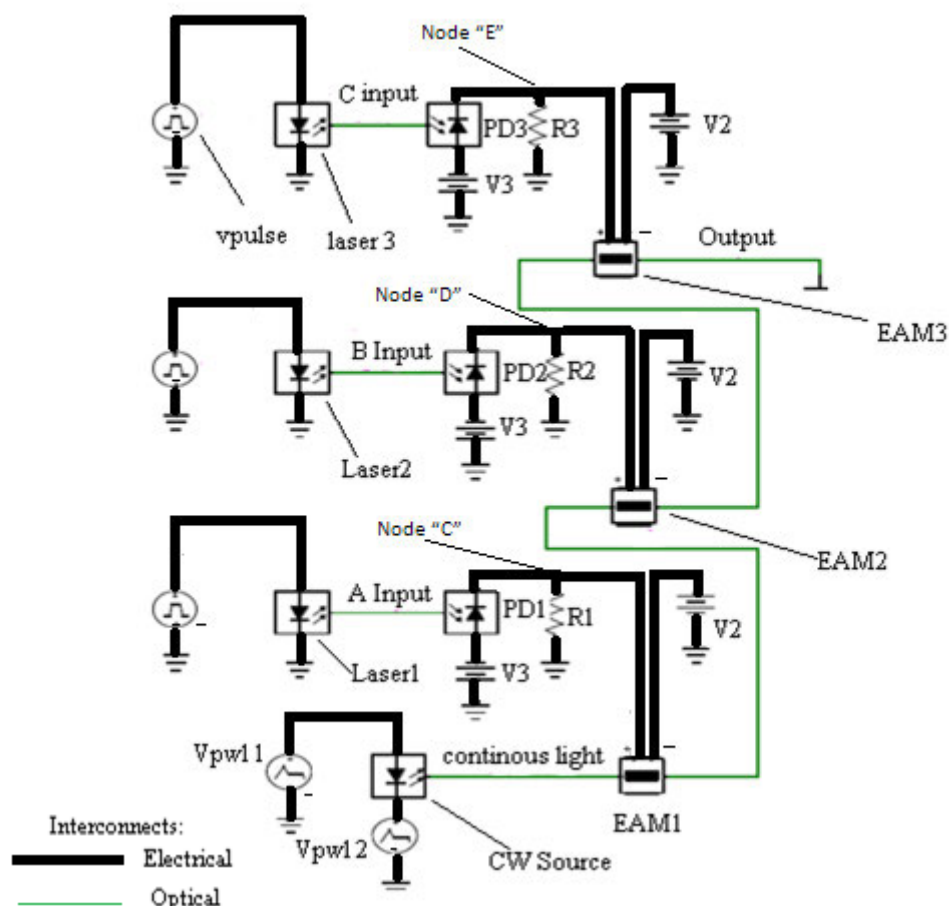

Figure 4. Optical 3-input NOR gate

Three pairs of EAM/PD were used in the proposed optical three-input NOR gate. The analysis and structure of the integrated photonic circuit of this gate is similar to optical two-input gate [1]. DC biased voltage V_3 (which equals 1V) was used for photodetectors (PDs 1, 2, 3), while, for electro-absorption modulators (EAMs 1, 2, 3), DC biased voltage V_2 (which equals -1V) was utilized. Optical power of the input opti-digital lasers (Lasers 1, 2, 3) that have been biased with biased voltage V_{pulse} and operate in wavelength 800 nm is about 40mw. Also, the resistances R_1 to R_3 are all equal to 30 Ohms. The results of the simulation of the circuit of figure 4 can be found in table 1; the numbers inserted in the given table are average input and output powers.

Table 1. Results of the measurements of 3-input optical NOR gate (The power of optic-digital laser 40.139×10^{-3} w and the power of continuous wave optical laser 40.200×10^{-3} w)

A	B	C	D
120.886×10^{-12}	120.886×10^{-12}	120.886×10^{-12}	40.400×10^{-3}
76.757×10^{-12}	76.757×10^{-12}	40.139×10^{-3}	101.844×10^{-6}
76.757×10^{-12}	40.139×10^{-3}	76.757×10^{-12}	101.845×10^{-6}
76.720×10^{-12}	40.139×10^{-3}	40.139×10^{-3}	100.195×10^{-6}
40.139×10^{-3}	76.718×10^{-12}	76.718×10^{-12}	101.845×10^{-6}
40.139×10^{-3}	76.758×10^{-12}	40.139×10^{-3}	100.195×10^{-6}
40.139×10^{-3}	40.139×10^{-3}	76.758×10^{-12}	100.195×10^{-6}
40.036×10^{-3}	40.036×10^{-3}	40.036×10^{-3}	100.008×10^{-6}

In this optical gate minimum optical power amounts ($\sim 76 \times 10^{-12}$ w) to logical “zero” while the maximum amount ($\sim 40.14 \times 10^{-3}$ w) will be logical “one”. Therefore, table 1 is corresponding and equivalent to truth table of electronic 3-input NOR gate.

3.3 Optical NOT gate

One pair of optical waveguide devices on a substrate, connected in series to operate as an optical NOT gate and consisting of an electro-absorption modulator and a photodetector, form an optical NOT gate [1].

3.4 Proposed optical reversible R gate

Quite a few number of reversible gates, including the Toffoli gate, the Fredkin gate and etc. have been proposed over the past years. The present study puts forth a 3-input and 3-output reversible logic gate. As it is shown in Figure 5, inputs include A, B, C and outputs X, Y and Z. The truth table of the gate is shown in Table 2. The output expressions of a reversible R gate are as follows:

$$X = A'B + AB' \quad (3)$$

$$Y = A \quad (4)$$

$$Z = B'C' + C'A' + ABC \quad (5)$$

Figure 5 manifests a schematic diagram of the electrical and optical circuit of the optical reversible R gate. The Optispice simulations results of the proposed circuit have been inserted in Table 2. It can be easily recognized that these results are the same as truth table of R gate.

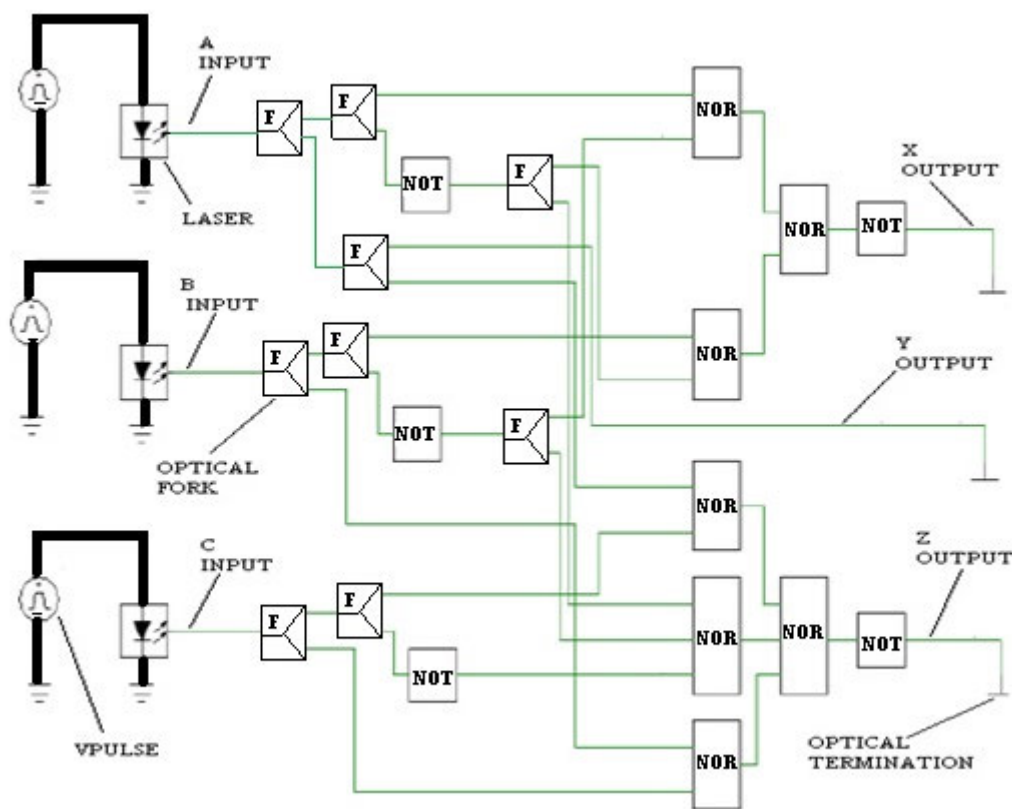

Figure 5. Proposed optical R gate

Table 2. Optispice simulation results of proposal optical R gate

A	B	C	X	Y	Z
120.886×10^{-12}	120.886×10^{-12}	120.886×10^{-12}	64.162×10^{-12}	120.886×10^{-12}	40.200×10^{-3}
76.778×10^{-12}	76.778×10^{-12}	40.097×10^{-3}	76.778×10^{-12}	76.778×10^{-12}	76.778×10^{-12}
76.701×10^{-12}	40.097×10^{-3}	76.701×10^{-12}	39.624×10^{-3}	76.701×10^{-12}	40.079×10^{-3}
76.701×10^{-12}	40.097×10^{-3}	40.097×10^{-3}	40.033×10^{-3}	76.701×10^{-12}	369.423×10^{-6}
40.097×10^{-3}	76.702×10^{-12}	76.702×10^{-12}	40.033×10^{-3}	40.033×10^{-3}	40.033×10^{-3}
40.097×10^{-3}	76.701×10^{-12}	40.097×10^{-3}	40.034×10^{-3}	40.097×10^{-3}	369.379×10^{-6}
40.097×10^{-3}	40.097×10^{-3}	76.701×10^{-12}	76.701×10^{-12}	40.097×10^{-3}	76.701×10^{-12}
40.010×10^{-3}	40.010×10^{-3}	40.010×10^{-3}	594.174×10^{-9}	40.010×10^{-3}	40.457×10^{-3}

4. A comparison between optical R gate and electronic R gate

Implementation of the given circuit has been done through using CMOS transistors with $0.25\mu m$ technology; meanwhile, $W=99\mu m$ and $L=0.25\mu m$ have been taken into consideration. C' AB Output was examined for the variation of the input from "011" to "111". According to comparison between input and output pulses the delay time is about 15ns. Figure 6, shows VLSI circuit of R gate.

On the other hand, based on the measurements, the delay time of optical R gate has been 3ns.

Figure 7, shows applied and output signals which used for measuring. Therefore, the delay time of the proposed optical R gate is remarkably lower than the delay time of its VLSI circuit.

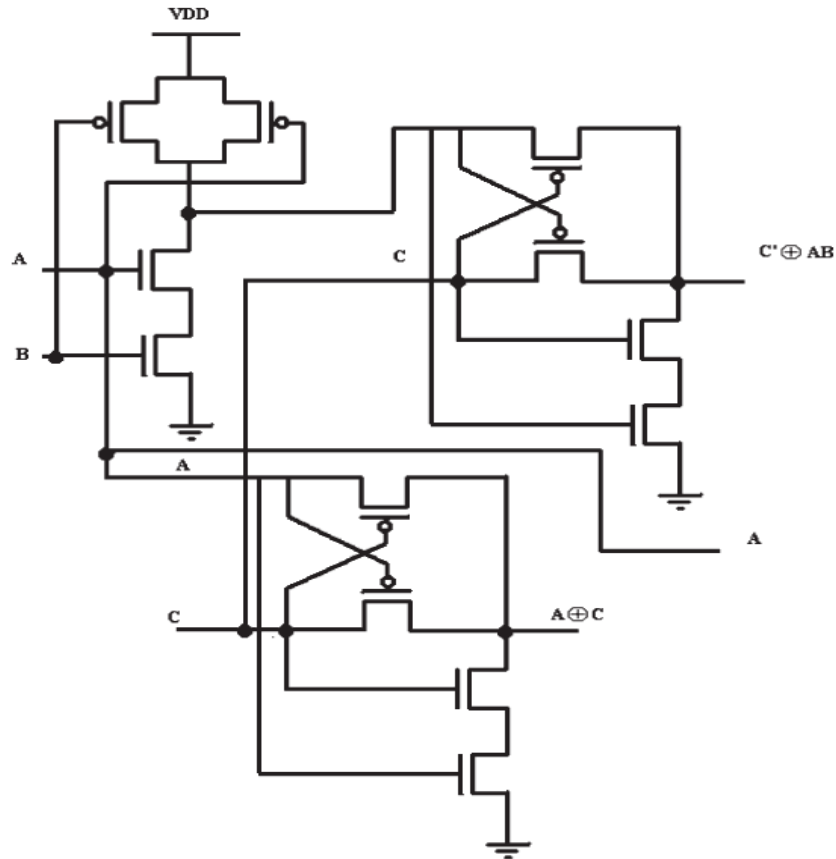
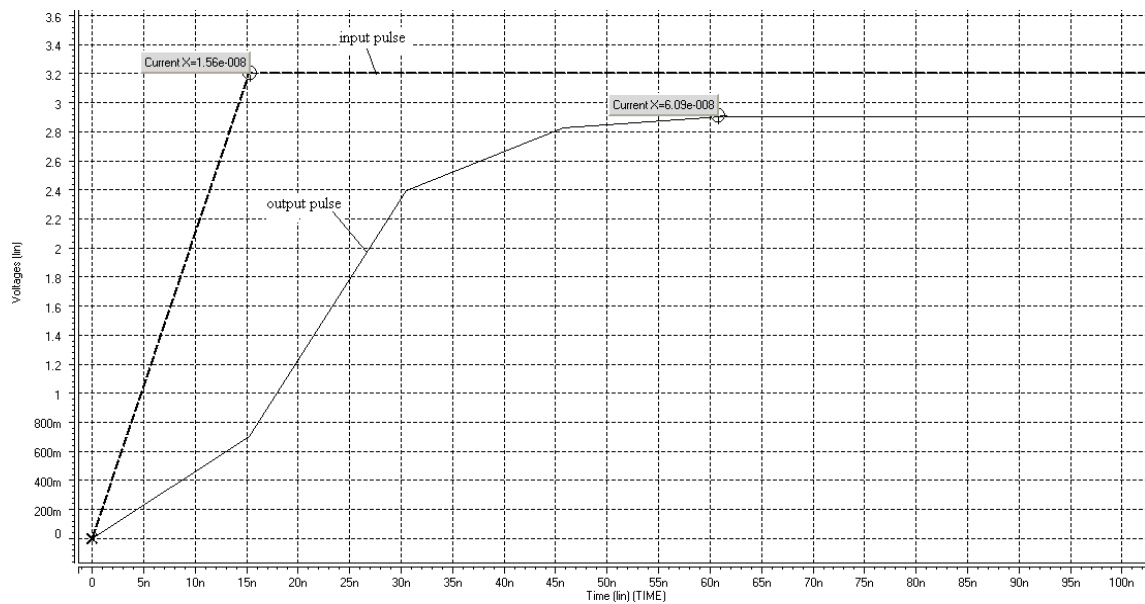

Figure 6: CMOS implementation of R gate [7].

4.1 Proposed reversible optical fulladder

Replacing optical R gate with electronic R gate in partial fulladder (Figure 2), a reversible optical fulladder is brought about so that the results of the simulations are compatible with the Truth Table of electronic fulladder. Similarly, all advantages in optical R gate can be achieved by the optical fulladder.



(a)

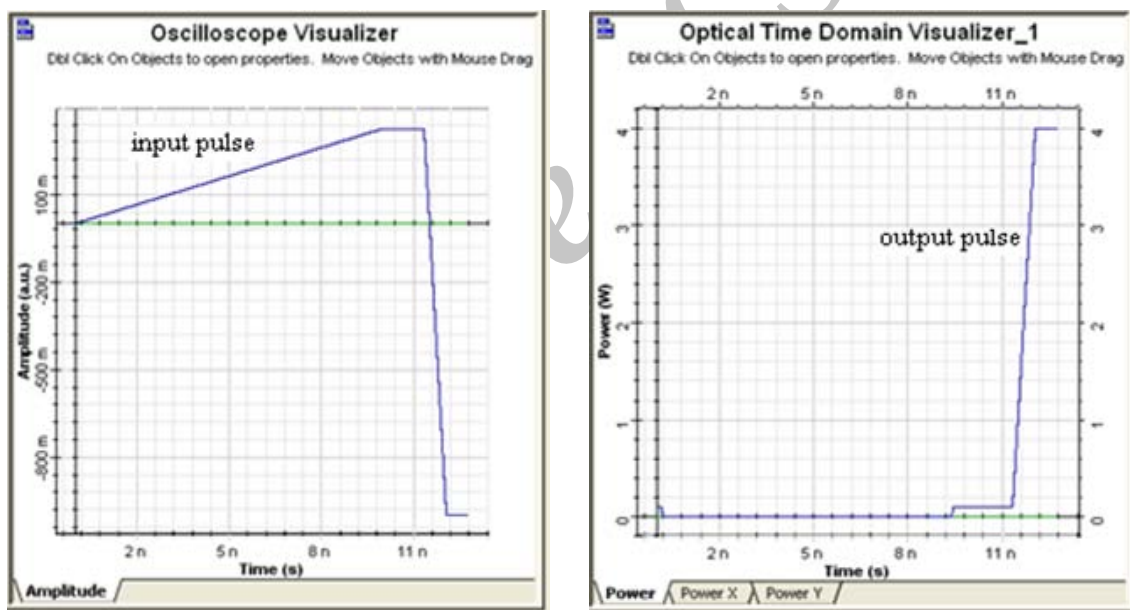

(b)

Figure 7: (a) input and output pulses of CMOS implementation of R gate, (b) input and output pulses of optical R gate .

5. Conclusion

In this study fulfilling a reversible optical fulladder using a pair of optical waveguide devices of EAM/PD was practiced. It was shown that using three pairs of EAM/PD, a 3-input NOR gate can be produced; then, exploiting optical NOT and NOR gates, we could design reversible R gate that were used in fulfilling reversible optical fulladder. The results of the measurements manifested that the delay time of the proposed optical gate equaled 3ns, while the delay time of VLSI circuit was 15ns. Therefore, there was a dramatic reduction in the delay time.

6. References

- [1] U.S. Patent application Ser.No.12/270,221, entitled "Optical NOR Gate," Sep. 2011, PP 12-19.
- [2] A. L. Lentine and Frank A. P. Tooley and F. B. McCormick and L. M. F. Chirovsky and L. Arthur D'Asaro and D. A. B Miller, "Logic Self-Electro optic Effect Devices: Quantum-Well Optoelectronic Multiport Logic Gates, Multiplexers, Demultiplexers, and Shift Registers, " IEEE Journal of quantum electronics, VOL. 28, NO. 6, June 1992, PP 1-15.
- [3] Jeffry. S. Powell, "Systems Applications of Vertical Cavity Multi Quantum Well Optoelectronic Modulators," For The degree of doctor of philosophy, Sep. 1997, PP 26-33.
- [4] P. K. Lala and J. P. Parkerson and P. Chakraborty, "Adder Designs using Reversible Logic Gates," WSEAS Trans. on circuits and Systems, Issue 6, Volume 9, June 2010, PP 1-8.
- [5] O. Fidaner and H. V. Demir and V. A. Sabnis and J. S. Harris and D. A. B. Miller, "Multifunctional Integrated Photonic Switches for Nanosecond Packet-Switched Wavelength Conversion," Optical Society of America, 2005, PP 1-3.
- [6] H. V. Demir and V. A. Sabnis and O. Fidaner, and D. A. B. Miller, "Multifunctional Integrated Photonic Switches, " IEEE Journal of selected topics in quantum electronics, Vol. 11, NO. 1, January /February 2005, PP 1-10.
- [7] D. P. Vasude Van, P. K. Lala, Jia Di and J. P. Parkerson, "Reversible-Logic Design With Online Testability, " IEEE Trans. on instrumentation and measurement, Vol. 55, NO. 2, April 2006, PP 1-7.

SID



سرویس های ویژه



سرویس ترجمه تخصصی



کارگاه های آموزشی



بلاگ مرکز اطلاعات علمی



عضویت در خبرنامه



فیلم های آموزشی

کارگاه های آموزشی مرکز اطلاعات علمی جهاد دانشگاهی



آموزش آنلاین ابزار پژوهش کمی (کاربره نرم افزار SPSS)

کارگاه آنلاین کاربرد نرم افزار SPSS در پژوهش

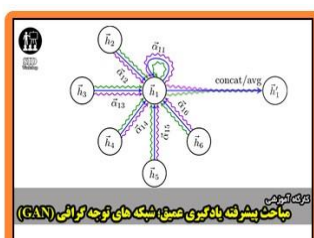

مباحث پیشرفته یادگیری عمیق شبکه های توجه گرافی (GAN)

مباحث پیشرفته یادگیری عمیق؛ شبکه های توجه گرافی (Graph Attention Networks)



مقاله نویسی ISI (روزه علمی مهندسی)

کارگاه آنلاین مقاله نویسی ISI و IEEE و مهندسی